



RỒNG VÀNG
TECHNOLOGY



Connectors ARINC600

SB6 Series

www.rong-vang-technology.vn



CONNECTOR ARINC600, SB6 SERIES



Product introduction

Compliant with ARINC600 standard

Error-proof using hexagonal encoding with 99 error-proof keys

Different materials and coatings can be selected for the housing to suit different environmental requirements

Mix common low frequency, power supply, high frequency, high speed differential and light contact parts for integrated signal transmission

Modular structure design allows users to choose different combinations of modules according to their usage requirements

Standard #8 RF contacts use frequency 0 ~ 500 MHz, floating RF contacts #8 use frequency 0 ~ 18 GHz



Technical features

Endurance: 500 mating cycles

Shock: 11 ms half sine wave acceleration 50 g

Vibration:

- Functional vibration: 15-2000 Hz, power spectral density 0.126 G²/Hz, duration 6 h
- Durable vibration: 15-2000 Hz, power spectral density 0.201 G²/Hz, duration 7.5 h

Temperature range: -65°C ~ +150°C

Resistance to salt spray:

- Class F: 96 h
- Class W: 500 h
- Class M: 192 h (acidic atmosphere)

Fluid resistance: oil, multiple fuels, cooling fluids, etc.

Insulation resistance: > 5000 MΩ (500 V DC)

Rated current, contact resistance, voltage resistance of low frequency contacts

Contact Size	Wire gauge (AWG)	Rated current, A	Contact Resistance Max, mΩ	Withstanding Voltage (V)		
				Sea level	15000 m	30480 m
#22	26	2	11	1300	500	-
	24	3				
	22	5				
#20	24	3	8.5	1500	500	-
	22	5				
	20	7.5				
#16	16	13	5	1500	-	500
#12	12	23	2.5	1500	-	500

High Speed Differential Signal

Transfer Rate	1.65 Gbps	Near-end Crosstalk	≥30 dB
Impedance	100 Ω	Insertion Loss	≤0.5 dB (250 MHz)

CAN bus signal and ARINNC429 signal

Transfer Rate	1 Mbps	
Characteristic Impedance	120 Ω	
Rated Voltage	50 V	
Electromagnetic Shielding Interference (dB/min)	800 MHz ~ 1000 MHz	50 dB
	300 MHz ~ 400 MHz	51 dB
	200 MHz	53 dB
	100 MHz	55 dB



1553B Signal

Transfer Rate		1 Mbps
Characteristic Impedance		70 ~ 85 Ω
Rated Operational Voltage	Sea level	500 V
	21000 m	125 V
Pressure Drop	Center contact	<55 mV/1 A
	Intermediate contact	<55 mV/1 A
	Outer contact	<75 mV/12 A

High Frequency Signal

Specification of coaxial contact parts		coaxial #8	coaxial #5	coaxial #1
Impedance		50 Ω		50 Ω
bandwidth		0 ~ 500 MHz		0 ~ 2 GHz
withstanding voltage	Sea level	750 V		
Drop	Center contact	≤ 10 m Ω		
	Outer contact	≤ 1.5 m Ω		
Standing-wave Ratio		≤ 1.3		≤ 1.5
Insertion Loss		≤ 0.3 dB		

Optical Signal

optical contact parts	#16 Fiber optic contact	A8T Fiber optic contact
Insertion loss (singlemode)	≤ 1.5 dB	
Insertion loss (multimode)	≤ 1.2 dB	



Ordering information

Basic series	SB6	N	G	F	2	TS	Y	0095	02	F	-S	-G
Sealing Level:												
Omit = Sealed												
N = Unsealed												
Type of arrangement:												
Omit = Electrical connectors												
G = Optoelectronic mixed packaging												
Plating:												
F = Electroless nickel												
W = Cadmium												
M = Resistant to marine environment												
Shell Size: 1, 2, 3												
Shell Type:												
TS = Rack plug												
ZP = Equipment receptacle												
Contact Mounting & Release:												
Y = Crimp												
B = Remove the printed board												
B1 = Front unloading printed board (pin length 3.8mm)												
B2 = Front unloading printed board (pin length 7.3mm)												
B3 = Front unloading printed board (pin length 9.5mm)												
B4 = Front unloading printed board (pin length 12.7mm)												
Inserts Arrangement Code												
Polarization Code												
Mounting Style:												
Omit = Standard Installation												
F = Floating installation (floating amount ± 0.25 mm)												
F01 = Large floating installation (floating amount ± 0.75 mm)												
Shielding device:												
Omit = Unshielded product												
S = Shielded products (plug only)												
Installation hole type:												
Omit = Through hole installation												
G = M3 threaded hole installation												
Modification design serial number:												
Omit = Standard Modification												
01, 02, 03 = Modification												

Note 1: The type of printed board is only limited to SB6-1, SB6-2 and SB6-3 series sockets, and there is no printed board type for plugs

Note 2: Removing the printed board before class B2 can replace removing the printed board after class B



Example of model marking

SB6GM2TSY0199-S-G: SB6-2 series plug, product combination code 0199, coating is marine environment resistant coating, plug hole installation, termination method is crimping, plug is sealed shielding photoelectric mixed installation plug, positioning key position is default 01 key position, installation method is M3 threaded hole installation.

Note

- 1. Install pins for connector plug #22 contacts and holes for other contacts; Install holes for socket #22 contacts and pins for other contacts. When naming connectors, the #22 contact type is not taken into account, and other specifications of contact parts shall prevail.*
- 2. The finished connector products only provide conventional contacts such as #22, #20, #16, and #12, and special contacts such as high-frequency, coaxial, differential, and optical fibers that are compatible need to be ordered separately.*
- 3. There is no locking mechanism between the plug and socket of this series of connectors, and the connector locking is achieved through the locking mechanism of its supporting equipment. The installation method and size of the plug and socket in place are shown in Figure 1.*
- 4. The SB6 series metal frame connector is installed on the panel through screws, and the recommended installation method for sockets is to install them from behind the board, that is, from inside the chassis. The recommended installation method for plugs is backboard installation. (Note: The positioning reference for the installation surface of the plug and socket is the square protrusion on the shell of the plug and socket square plate, which needs to be ensured that the square protrusion of the plug and socket and the bottom surface of the chassis are located on the same horizontal plane, as shown in Figure 1. This can ensure that the product design reference, part processing reference, connector installation reference, and the theoretical insertion reference of the chassis and installation bracket are consistent, and ensure the smooth insertion and engagement of the connector.)*
- 5. For standard products, the installation and positioning dimensions cannot be based on the installation holes. If a floating product is selected, in order to ensure the floating effect of the product, the floating range is $\pm 0.25\text{mm}$ for the product. Only four to six installation holes can be selected for installation on the flange plate. If individual users choose to install horizontally, it is important to ensure that the plug is at least 0.5mm above the socket in the vertical direction. Because there may be gaps during the actual insertion process between the chassis and the bottom surface of the mounting bracket, it is impossible to fully fit.*
- 6. During the connector insertion process, if there is any problem with smooth insertion, you can press the rear of the chassis to slightly lift the front of the chassis before inserting it into the plug on the installation rack. If it can be directly and smoothly inserted, there is no need to follow this operation. (However, please note that if the size design of the chassis and mounting bracket is not reasonable, causing the socket to be located above the plug when the chassis and mounting bracket are plugged in, it is difficult to ensure smooth insertion.)*

Insert layouts

Shell size 2 & 3
Cavity A, B, D & E

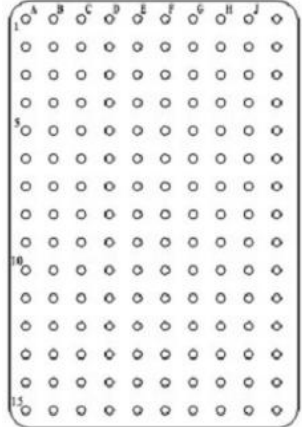
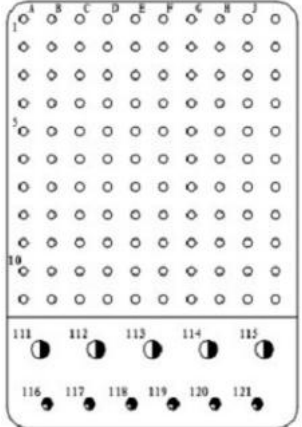
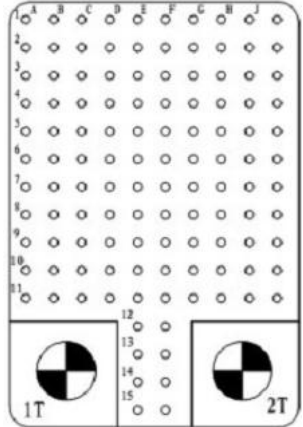
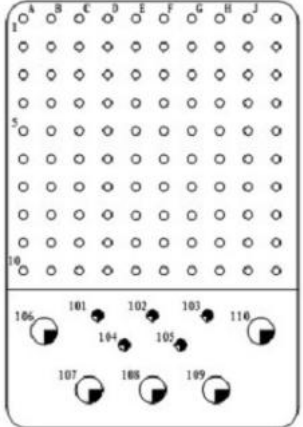
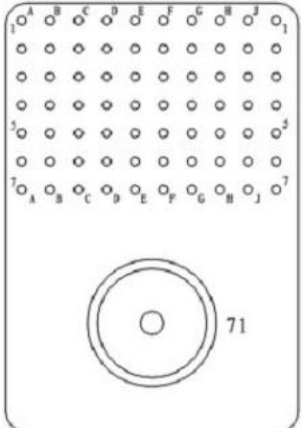
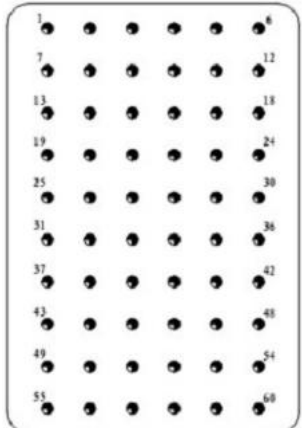
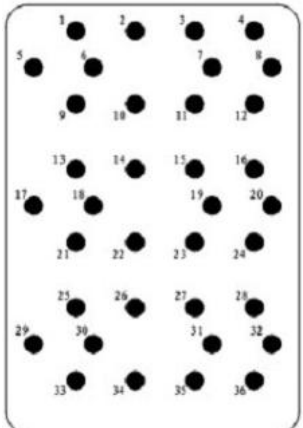
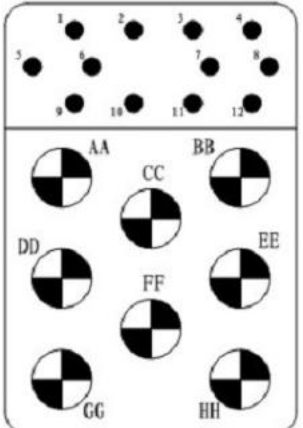
<p style="text-align: center;">I-150</p> 	<p style="text-align: center;">I-121</p> 	<p style="text-align: center;">I-120T2</p> 	<p style="text-align: center;">I-110</p> 
<p style="text-align: center;">150 – #22</p>	<p style="text-align: center;">110 – #22, 6 – #20, 5 – #16</p>	<p style="text-align: center;">118 – #22, 2 – #8</p>	<p style="text-align: center;">100 – #22, 5 – #20, 5 – #12</p>
<p style="text-align: center;">I-70C1</p> 	<p style="text-align: center;">I-60</p> 	<p style="text-align: center;">I-36G36</p> 	<p style="text-align: center;">I-20F12T8</p> 
<p style="text-align: center;">70 – #22, 1 – #1</p>	<p style="text-align: center;">60 – #20</p>	<p style="text-align: center;">36 – A8T</p>	<p style="text-align: center;">12 – A8T, 8 – #8</p>

Shell size 2 & 3
Cavity A, B, D & E

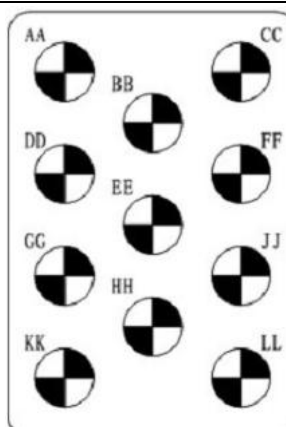
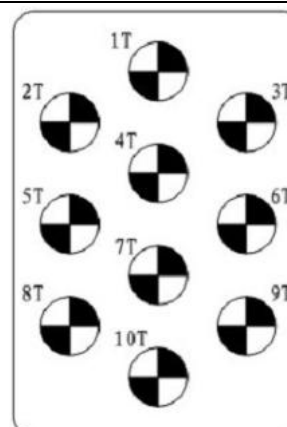
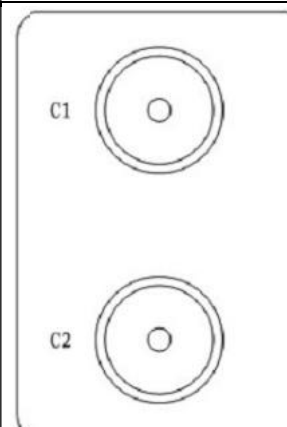
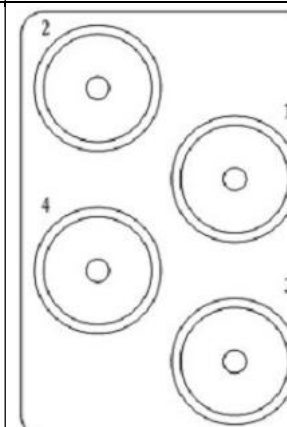
I-11T11	I-10T10	I-C2	I-C4
			
11 - #8	10 - #8	2 - #1	4 - #1

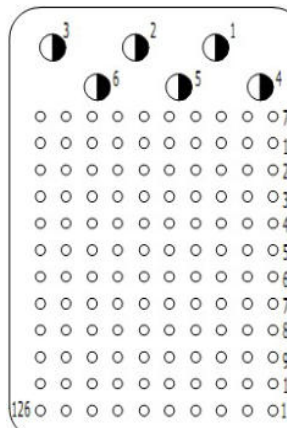
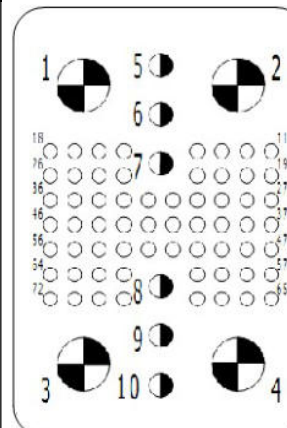
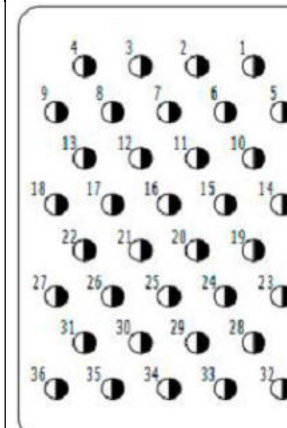
I-0	I-126	I-72T4	I-36A
			
Dummy Insert	122 - #22, 6 - #16	62 - #22, 6 - #16, 4 - #8	36 - #16

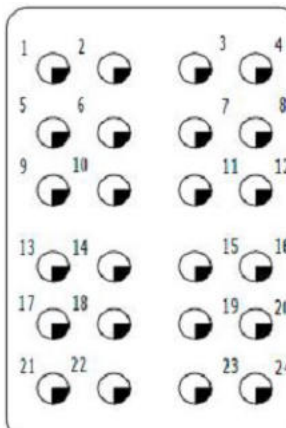
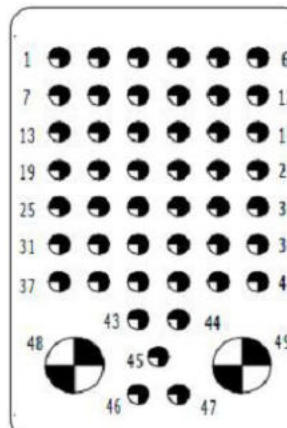
I-24	I-47T2
	
24 - #12	47 - #20, 2 - #8

Shell size 2 & 3
Cavity C & F

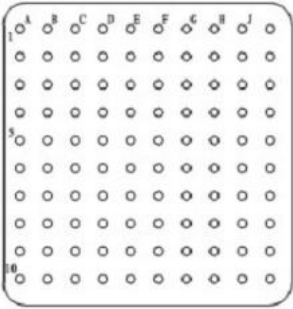
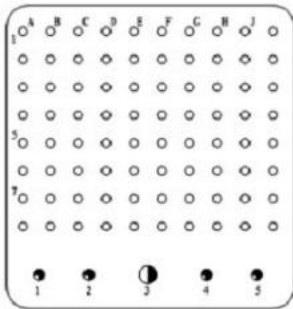
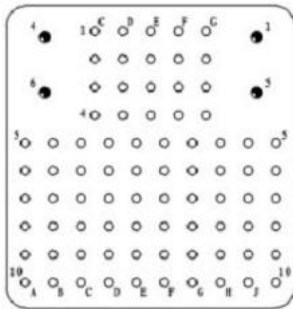
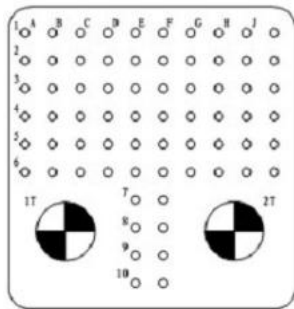
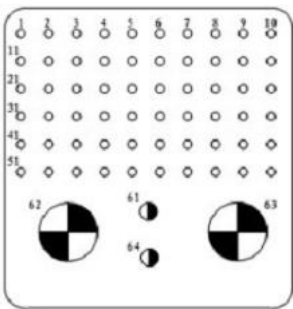
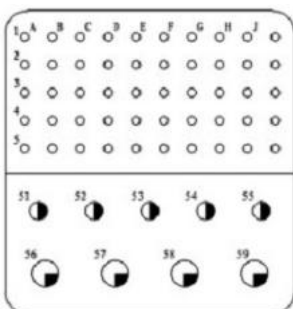
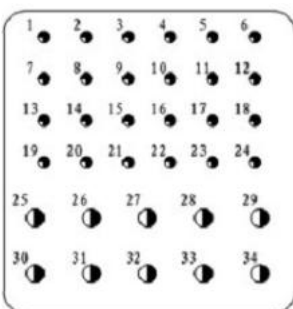
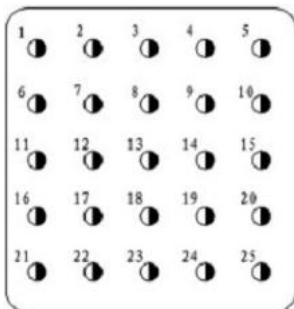
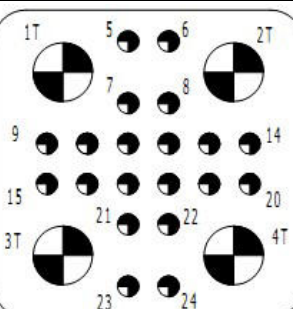
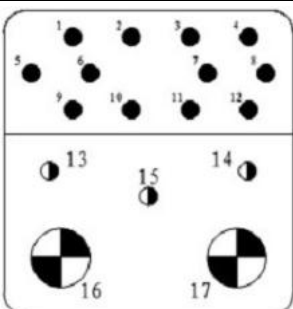
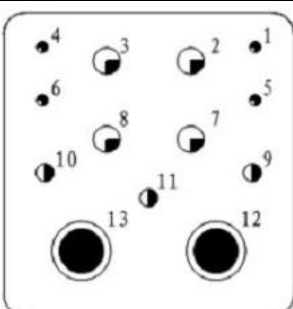
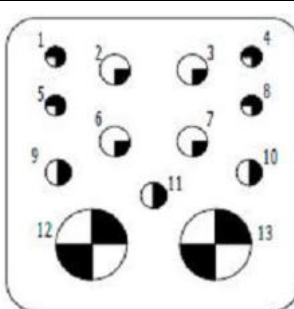
<p style="text-align: center;">II-100</p> 	<p style="text-align: center;">II-85</p> 	<p style="text-align: center;">II-84</p> 	<p style="text-align: center;">II-70T2</p> 
<p style="text-align: center;">100 - #22</p>	<p style="text-align: center;">80 - #22, 4 - #20, 1 - #16</p>	<p style="text-align: center;">80 - #22, 4 - #20</p>	<p style="text-align: center;">68 - #22, 2 - #8</p>
<p style="text-align: center;">II-64T2</p> 	<p style="text-align: center;">II-59</p> 	<p style="text-align: center;">II-34</p> 	<p style="text-align: center;">II-25</p> 
<p style="text-align: center;">60 - #22, 2 - #16, 2 - #8</p>	<p style="text-align: center;">5 - #22, 5 - #16, 4 - #12</p>	<p style="text-align: center;">24 - #20, 10 - #16</p>	<p style="text-align: center;">25 - #16</p>
<p style="text-align: center;">II-20T4A</p> 	<p style="text-align: center;">II-17F12T2</p> 	<p style="text-align: center;">II-13W2</p> 	<p style="text-align: center;">II-11T2</p> 
<p style="text-align: center;">20 - #20, 4 - #8</p>	<p style="text-align: center;">12 - A8T, 3 - #16, 2 - #8</p>	<p style="text-align: center;">4 - #20, 3 - #16, 4 - #12, 2 - #5</p>	<p style="text-align: center;">4 - #20, 3 - #16, 4 - #12, 2 - #8</p>



Shell size 2 & 3
Cavity C & F

II-6T6	II-0	II-20T4	II-20T4G4
6 - #8	Dummy Insert	20 - #20, 4 - #8	20 - #20, 4 - #16, 4 - #8

Shell size 1
Cavity A, B

I-60	30-T2	I-W4	I-28	I-0
60 - #22	28 - #22, 2 - #8	4 - #5	28 - #20	Dummy Insert

Shell size 1
Cavity C

II-40	II-4	II-5W2	II-9	II-0
40 - #22	4 - #12	2 - #16, 1 - #12, 2 - #5	9 - #16	Dummy Insert



Inserts arrangement code. Size 1

Digit	Shell size	Insert arrangements					
		Cavity A	Cavity B	Cavity C	Cavity D	Cavity E	Cavity F
0005	1	I-0	I-0	II-5W2	–	–	–
0034	1	I-30T2	I-0	II-4	–	–	–
0037	1	I-0	I-28	II-9	–	–	–
0060	1	I-0	I-60	II-0	–	–	–
A060	1	I-60	I-0	II-0	–	–	–
0061	1	I-28	I-28	II-5W2	–	–	–
0065	1	I-0	I-60	II-5W2	–	–	–
A065	1	I-60	I-0	II-5W2	–	–	–
B065	1	I-30T2	I-30T2	II-5W2	–	–	–
0067	1	I-30T2	I-28	II-9	–	–	–
0069	1	I-30T2	I-30T2	II-9	–	–	–
C072	1	I-30T2	I-30T2	II-12KG12	–	–	–
0093	1	I-60	I-28	II-5W2	–	–	–
B094	1	I-60	I-30T2	II-4	–	–	–
0095	1	I-60	I-30T2	II-5W2	–	–	–
0096	1	I-28	I-28	II-40	–	–	–
0098	1	I-28	I-30T2	II-40	–	–	–
0099	1	I-A60	I-30T2	II-9	–	–	–
A100	1	I-60	I-30T2	II-11T2	–	–	–
A105	1	I-60	I-30T2	II-15	–	–	–
0120	1	I-60	I-60	II-0	–	–	–
0125	1	I-60	I-60	II-5W2	–	–	–
Q125	1	I-60	I-60	II-5Q2	–	–	–
0128	1	I-60	I-28	II-40	–	–	–
0129	1	I-60	I-60	II-9	–	–	–
0130	1	I-60	I-30T2	II-40	–	–	–
A130	1	I-60	I-60	I-10T2	–	–	–
0132	1	I-60	I-60	II-12KG12	–	–	–
0160	1	I-60	I-60	II-40	–	–	–



Inserts arrangement code. Size 2

Digit	Shell size	Insert arrangements					
		Cavity A	Cavity B	Cavity C	Cavity D	Cavity E	Cavity F
0013	2	I-0	I-0	II-13W2	–	–	–
0015	2	I-C2	I-0	II-11Q2	–	–	–
A016	2	I-6G6	I-6G6	II-4G4	–	–	–
0024	2	I-0	I-24	II-0	–	–	–
A042	2	I-C4	I-C4	II-34	–	–	–
0045	2	I-11T11	I-0	II-34	–	–	–
0046	2	I-11T11	I-11T11	II-20T4	–	–	–
0051	2	I-11T11	I-6G6	II-34	–	–	–
D052	2	I-10P10	I-36A	II-6P6	–	–	–
0054	2	I-24	I-24	II-6T6	–	–	–
B054	2	I-20F12T8	I-0	II-34	–	–	–
A056	2	I-11T11	I-11T11	II-34	–	–	–
A060	2	I-11T11	I-36	II-11T2	–	–	–
B060	2	I-36G36	I-0	II-20T4	–	–	–
0064	2	I-10T10	I-20F12T8	II-34	–	–	–
A064	2	I-0	I-0	II-64T2	–	–	–
0066	2	I-36A	I-24	II-6P6	–	–	–
A067	2	I-P4	I-P4	II-59	–	–	–
A070	2	I-11T11	I-0	II-59	–	–	–
B070	2	I-36G36	I-0	II-34	–	–	–
C070	2	I-0	I-0	II-70T2	–	–	–
B072	2	I-72T4	I-0	II-0	–	–	–
0074	2	I-47T2	I-0	II-25	–	–	–
0075	2	I-0	I-11T11	II-64T2	–	–	–
A075	2	I-0	I-11P11	II-64T2	–	–	–
0079	2	I-10P10	I-10P10	II-59	–	–	–
B079	2	I-0	I-20F12T8	II-59	–	–	–
0080	2	I-36G36	I-10T10	II-34	–	–	–
A080	2	I-36G36	I-10P10	II-34	–	–	–
B080	2	I-10T10	I-0	II-70T2	–	–	–
0081	2	I-11T11	I-11T11	II-59	–	–	–
A081	2	I-6M6	I-11T11	I-64T2	–	–	–
B081	2	I-11Q11	I-11Q11	II-59	–	–	–
0084	2	I-10T10	I-10T10	II-64T2	–	–	–
A084	2	I-60	I-11T11	II-13W2	–	–	–
B084	2	I-20F12T8	I-0	II-64T2	–	–	–
C084	2	I-10T10	I-11Q11	II-13W2	–	–	–
0085	2	I-10T10	I-16T16	II-59	–	–	–
0086	2	I-11T11	I-11T11	II-64T2	–	–	–
A086	2	I-24	I-36	II-25	–	–	–



Digit	Shell size	Insert arrangements					
		Cavity A	Cavity B	Cavity C	Cavity D	Cavity E	Cavity F
B086	2	I-11P11	I-11P11	II-64T2	–	–	–
0087	2	I-72T4	I-11T11	II-4G4	–	–	–
0090	2	I-11T11	I-20F12T8	II-59	–	–	–
0092	2	I-11T11	I-11T11	II-70T2	–	–	–
A092	2	I-36	I-36	II-20T4	–	–	–
A094	2	I-0	I-60	II-34	–	–	–
C094	2	I-10T10	I-70C1	II-13W2	–	–	–
E094	2	I-60	I-0	II-34	–	–	–
0095	2	I-36G36	I-0	II-64T2	–	–	–
C095	2	I-10T10	I-C2	II-13W2	–	–	–
0096	2	I-11T11	I-60	II-25	–	–	–
B096	2	I-20F12T8	I-72T4	II-4G4	–	–	–
A099	2	I-24	I-11T11	II-64T2	–	–	–
0100	2	I-0	I-0	II-100	–	–	–
0104	2	I-20F12T8	I-60	II-20T4A	–	–	–
0105	2	I-11T11	I-60	II-34	–	–	–
B105	2	I-10T10	I-36G36	II-59	–	–	–
C105	2	I-11P11	I-60	II-34	–	–	–
0106	2	I-72T4	I-0	II-34	–	–	–
0107	2	I-24	I-24	II-59	–	–	–
A107	2	I-88	I-19T4	II-0	–	–	–
0108	2	I-36G36	I-72T4	II-0	–	–	–
0112	2	I-6G6	I-6G6	II-100	–	–	–
A112	2	I-72T4	I-6G6	II-34	–	–	–
A114	2	I-60	I-20F12T8	II-34	–	–	–
0116	2	I-110	I-0	II-6T6	–	–	–
0118	2	I-24	I-24	II-70T2	–	–	–
A120	2	I-10T10	I-10T10	II-100	–	–	–
B120	2	I-60	I-47T2	II-11T2	–	–	–
C120	2	I-36	I-0	II-84	–	–	–
D120	2	I-120T2	I-0	II-0	–	–	–
0122	2	I-11T11	I-11T11	II-100	–	–	–
A122	2	I-72T4	I-16T16	II-34	–	–	–
B122	2	I-11T11	I-11T11	II-100	–	–	–
0127	2	I-121	I-0	II-6T6	–	–	–
A127	2	I-110	I-11T11	II-6T6	–	–	–
0131	2	I-121	I-C4	II-6T6	–	–	–
A131	2	I-11T11	I-36	II-84	–	–	–
B131	2	I-121	I-10T10	II-0	–	–	–
C131	2	I-11T11	I-20F12T8	II-100	–	–	–
D131	2	I-11P11	I-36	II-84	–	–	–
0133	2	I-60	I-60	II-13W2	–	–	–
0135	2	I-120T2	I-C2	II-13W2	–	–	–
A135	2	I-0	I-120T2	II-0	–	–	–



Digit	Shell size	Insert arrangements					
		Cavity A	Cavity B	Cavity C	Cavity D	Cavity E	Cavity F
0137	2	I-121	I-10T10	II-6T6	–	–	–
A137	2	I-72T4	I-6G6	II-59	–	–	–
B137	2	I-C4	I-120T2	II-13W2	–	–	–
C137	2	I-126	I-11T11	II-0	–	–	–
0138	2	I-121	I-11T11	II-6T6	–	–	–
A138	2	I-72T4	I-P4	II-62F12	–	–	–
T141	2	I-120T2	I-10T10	II-13W2	–	–	–
0143	2	I-10T10	I-120T2	II-13W2	–	–	–
A143	2	I-126	I-11T11	II-6T6	–	–	–
0144	2	I-120T2	I-11T11	II-13W2	–	–	–
A144	2	I-60	I-60	II-20T4A	–	–	–
B144	2	I-120T2	I-11T11	II-11T2	–	–	–
C144	2	I-11T11	I-120T2	II-11T2	–	–	–
D144	2	I-120T2	I-11T11	II-11T2	–	–	–
G144	2	I-120T2	I-0	II-20T4	–	–	–
K144	2	I-11T11	I-120T2	II-C11T2	–	–	–
0150	2	I-0	I-150	II-0	–	–	–
A150	2	I-150	I-0	II-0	–	–	–
B150	2	I-120T2	I-24	II-6T6	–	–	–
0151	2	I-121	I-24	II-6T6	–	–	–
A151	2	I-126	I-0	II-25	–	–	–
B151	2	I-0	I-126	II-25	–	–	–
C151	2	I-11T11	I-120T2	II-20T4G4	–	–	–
0154	2	I-60	I-60	II-34	–	–	–
0155	2	I-70C1	I-70C1	II-13W2	–	–	–
A155	2	I-60	I-36A	II-59	–	–	–
B155	2	I-11T11	I-110	II-34	–	–	–
C155	2	I-1C71	I-1C71	II-13W2	–	–	–
0156	2	I-120T2	I-11T11	II-25	–	–	–
A160	2	I-10T10	I-150	II-0	–	–	–
0162	2	I-126	I-11T11	II-13W2	–	–	–
A162	2	I-126	I-11T11	II25	–	–	–
B162	2	I-150	I-6G6	II-6T6	–	–	–
0163	2	I-0	I-150	II-13W2	–	–	–
A163	2	I-150	I-0	II-13W2	–	–	–
0165	2	I-150	I-C2	II-11T2	–	–	–
A165	2	I-11T11	I-120T2	II-34	–	–	–
B165		I-150	I-C2	II-11T2	–	–	–
C165	2	I-150	I-11T11	II-4G4	–	–	–
D165	2	I-150	I-0	II-11T2	–	–	–
0166	2	I-20F12T8	I-121	II-25	–	–	–
0167	2	I-150	I-C4	II-13W2	–	–	–
0168	2	I-60	I-47T2	II-59	–	–	–
B168	2	I-72T4	I-72T4	II-20T4	–	–	–



Digit	Shell size	Insert arrangements					
		Cavity A	Cavity B	Cavity C	Cavity D	Cavity E	Cavity F
0171	2	I-11T11	I-60	II-100	–	–	–
0172	2	I-36G36	I-36G36	II-100	–	–	–
0173	2	I-150	I-10T10	II-13W2	–	–	–
A173	2	I-10T10	I-150	II-13W2	–	–	–
B173	2	I-10T10	I-150	II-11T2	–	–	–
0174	2	I-150	I-11T11	II-13W2	–	–	–
A174	2	I-150	I-24	II-0	–	–	–
B174	2	I-24	I-150	II-0	–	–	–
0175	2	I-150	I-0	II-25	–	–	–
B179	2	I-16T16	I-150	II-11T2	–	–	–
0181	2	I-150	I-11T11	II-20T4A	–	–	–
A181	2	I-11T11	I-150	II-20T4G4	–	–	–
0182	2	I-120T2	I-47T2	II-11T2	–	–	–
0183	2	I-110	I-11T11	II-62F12	–	–	–
A184	2	I-60	I-24	II-100	–	–	–
B184	2	I-150	I-0	II-34	–	–	–
0185	2	I-10T10	I-150	II-25	–	–	–
0186	2	I-150	I-11T11	II-25	–	–	–
B184	2	I-150	I-0	II-34	–	–	–
0185	2	I-10T10	I-150	II-25	–	–	–
0186	2	I-150	I-11T11	II-25	–	–	–
A186	2	I-11T11	I-150	II-25	–	–	–
0187	2	I-121	I-60	II-6P6	–	–	–
0192	2	I-36G36	I-150	II-6T6	–	–	–
0194	2	I-120T2	I-47T2	II-25	–	–	–
A194	2	I-150	I-20F12T8	II-20T4	–	–	–
0195	2	I-150	I-11T11	II-34	–	–	–
A195	2	I-11T11	I-150	II-34	–	–	–
0199	2	I-20F12F8	I-120T2	II-59	–	–	–
A199	2	I-120T2	I-20F12T8	II-59	–	–	–
0204	2	I-150	I-20F12T8	II-34	–	–	–
0208	2	I-24	I-150	II-34	–	–	–
0210	2	I-150	I-36G36	II-20T4	–	–	–
A210	2	I-36G36	I-150	II-20T4A	–	–	–
0215	2	I-121	I-60	II-34	–	–	–
0220	2	I-150	I-0	II-70T2	–	–	–
A220	2	I-150	I-11T11	II-59	–	–	–
0221	2	I-121	I-0	II-100	–	–	–
0224	2	I-88	I-36G36	II-100	–	–	–
0225	2	I-11T11	I-150	II-64T2	–	–	–
0229	2	I-150	I-20F12T8	II-59	–	–	–
A231	2	I-150	I-11T11	II-70T2			
0233	2	I-150	I-60	II-13W2			
A233	2	I-150	I-24	II-59			



Digit	Shell size	Insert arrangements					
		Cavity A	Cavity B	Cavity C	Cavity D	Cavity E	Cavity F
B233	2	I-150	I-70C1	II-13W2			
0234	2	I-150	I-70C1	II-13W2			
A234	2	I-150	I-60	II-20T4			
0236	2	I-10T10	I-126	II-100			
0238	2	I-24	I-150	II-64T2			
0240	2	I-120T2	I-36A	II-84			
A240	2	I-20F12T8	I-150	II-70T2			
0244	2	I-150	I-60	II-34			
0245	2	I-150	I-36G36	II-59			
0246	2	I-120T2	I-120T2	II-6T6	–	–	–
0247	2	I-150	I-72T4	II-25	–	–	–
0248	2	I-121	I-121	II-6T6	–	–	–
0250	2	I-0	I-150	II-100	–	–	–
A250	2	I-150	I-0	II-100	–	–	–
B250	2	I-60	I-120T2	II-70T2	–	–	–
0252	2	I-126	I-126	II-0	–	–	–
0253	2	I-120T2	I-120T2	II-13W2	–	–	–
A254	2	I-120T2	I-72T4	II-62F12	–	–	–
B254	2	I-150	I-20F12T8	II-84A			
0255	2	I-121	I-121	II-13W2			
B255	2	I-20F12T8	I-150	II-85			
0256	2	I-36G36	I-150	II-70T2			
0260	2	I-150	I-10T10	II-100			
0261	2	I-150	I-11T11	II-100			
0262	2	I-126	I-36	II-100			
A264	2	I-120T2	I-120T2	II-20T4A			
0265	2	I-120T2	I-120T2	II-25	–	–	–
0266	2	I-150	I-110	II-6T6	–	–	–
A270	2	I-150	I-20F12T8	II-100	–	–	–
A271	2	I-36G36	I-150	II-85	–	–	–
0275	2	I-121	I-60	II-34	–	–	–
0276	2	I-121	I-121	II-34	–	–	–
0277	2	I-121	I-150	II-6T6	–	–	–
0280	2	I-110	I-150	II-20T4G4	–	–	–
A282	2	I-150	I-126	II-6P6	–	–	–
0283	2	I-150	I-120T2	II-13W2	–	–	–
A283	2	I-120T2	I-150	II-13W2	–	–	–
0284	2	I-150	I-121	II-13W2	–	–	–
B284	2	I-150	I-110	II-20T4	–	–	–
C284	2	I-150	I-110	II-20T4A	–	–	–
D284	2	I-150	I-72T4	II-62F12	–	–	–
0286	2	I-150	I-72T4	II-64T2	–	–	–
A286	2	I-150	I-36G36	II-100	–	–	–
B286	2	I-36G36	I-150	II-100	–	–	–

Digit	Shell size	Insert arrangements					
		Cavity A	Cavity B	Cavity C	Cavity D	Cavity E	Cavity F
0289	2	I-110	I-120T2	II-59	–	–	–
0292	2	I-110	I-120T2	I-62F12	–	–	–
0294	2	I-150	I-110	II-34	–	–	–
B295	2	I-150	I-121	II-20T4	–	–	–
0300	2	I-150	I-150	II-0	–	–	–
0301	2	I-150	I-126	II-25	–	–	–
0304	2	I-150	I-120T2	II-34	–	–	–
0305	2	I-150	I-121	II-34	–	–	–
0306	2	I-150	I-150	II-6T6	–	–	–
0310	2	I-150	I-60	II-100	–	–	–
0313	2	I-150	I-150	II-13W2	–	–	–
B313	2	I-150	I-150	II-C11T2	–	–	–
0324	2	I-150	I-150	II-20T4	–	–	–
B324	2	I-150	I-150	II-20T4A	–	–	–
0325	2	I-120T2	I-120T2	II-85	–	–	–
0329	2	I-150	I-120T2	II-59	–	–	–
0334	2	I-150	I-150	II-34	–	–	–
A334	2	I-150	I-120T2	II-64T2	–	–	–
0340	2	I-120T2	I-120T2	II-100	–	–	–
0359	2#	I-150	I-150	II-59	–	–	–
0364	2	I-150	I-150	II-64T2	–	–	–
0370	2	I-150	I-120T2	II-100	–	–	–
A370	2	I-120T2	I-150	II-100	–	–	–
B370	2	I-150	I-150	II-70T2	–	–	–
0400	2	I-150	I-150	II-100	–	–	–



Inserts arrangement code. Size 3

Digit	Shell size	Insert arrangements					
		Cavity A	Cavity B	Cavity C	Cavity D	Cavity E	Cavity F
0026	3	I-0	I-0	II-13W2	I-0	I-0	II-13W2
A051	3	I-11T11	I-11T11	II-6T6	I-11T11	I-6G6	II-6T6
0056	3	I-11T11	I-11T11	II-6T6	I-11T11	I-11T11	II-6T6
0058	3	I-P2	I-P2	II-25	I-P2	I-P2	II-25
0061	3	I-36A	I-0	II-25	I-0	I-0	II-0
A061	3	I-36G36	I-0	II-25	I-0	I-0	II-0
A069	3	I-11T11	I-6G6	II-20T4A	I-11T11	I-11T11	II-6T6
0075	3	I-11T11	I-11T11	II-6T6	I-11T11	I-11T11	II-25
0077	3	I-11T11	I-11T11	II-13T4	I-11T11	I-11T11	II-20T4G4
A079	3	I-11T11	I-6G6	II-34	I-11T11	I-11T11	II-6T6
C084	3	I-11T11	I-11T11	II-6T6	I-11T11	I-11T11	II-34
0099	3	I-11T11	I-11T11	II-13W2	I-11T11	I-0	II-64T2
A110	3	I-10T10	I-6T6	II-6T6	I-10T10	I-72T4	II-6T6
B112	3	I-11T11	I-11T11	II-64T2	I-11T11	I-11T11	II-4G4
0113	3	I-0	I-0	II-100	I-0	I-0	II-13W2
A113	3	I-0	I-0	II-13W2	I-0	I-0	II-100
0133	3	I-11T11	I-11T11	II-25	I-11T11	I-11T11	II-64T2
0134	3	I-36A	I-11T11	II-6T6	I-11T11	I-11T11	II-59
0142	3	I-11P11	I-60	II-0	I-11P11	I-60	II-0
A149	3	I-P2	I-24	II-25	I-60	I-P4	II-34
0146	3	I-24	I-24	II-25	I-24	I-24	II-25
B166	3	I-20F12T8	I-6G6	II-20T4A	II-20F12T8	I-72T4	II-20T4A
0168	3	I-11T11	I-11T11	II-100	I-11T11	I-11T11	II-20T4
A168	3	I-11T11	I-11T11	II-20T4	I-11T11	I-11T11	II-100
0178	3	I-11T11	I-11T11	II-100	I-11T11	I-11T11	II-34
0179	3	I-121	I-24	II-6T6	I-11T11	I-11T11	II-6T6
A179	3	I-121	I-24	II-6P6	I-11P11	I-11P11	II-6P6
A183	3	I-P2	I-24	II-59	I-60	I-P4	II-34
0184	3	I-P4	I-47P2	II-25	I-60	I-24	II-20P4
C184	3	I-36A	I-36A	II-20T4G4	I-36A	I-36A	II-20T4G4
A185	3	I-60	I-36G36	II-13W2	I-60	I-10T10	II-6T6
0193	3	I-P4	I-47P2	II-34	I-60	I-24	II-20P4
0201	3	I-150	I-11T11	II-20T4	I-10T10	I-0	II-6T6
0214	3	I-150	I-11T11	II-6T6	I-11T11	I-11T11	II-25
0231	3	I-121	I-10T10	II-100	I-0	I-0	II-0
0232	3	I-36A	I-24	II-64T2	I-11T11	I-72T4	II-25
B233	3	I-10T10	I-72T4	II-25	I-60	I-60	II-6T6
0239	3	I-11T11	I-11T11	II-100	I-11T11	I-72T4	II-34
0240	3	I-0	I-0	II-20T4	I-72T4	I-110	II-34
0241	3	I-120T2	I-60	II-25	I-36A	I-0	II-0



Digit	Shell size	Insert arrangements					
		Cavity A	Cavity B	Cavity C	Cavity D	Cavity E	Cavity F
A241	3	I-120T2	I-60	II-25	I-36G36	I-0	II-0
A244	3	I-11T11	I-11T11	II-100	I-11T11	I-11T11	II-100
A246	3	I-11T11	I-11T11	II-4G4	I-11T11	I-150	II-59
O251	3	I-11T11	I-11T11	II-34	I-11T11	I-150	II-34
O254	3	I-110	I-110	II-6T6	I-11T11	I-11T11	II-6T6
A255	3	I-150	I-0	II-70T2	I-11T11	I-0	II-20T4
O263	3	I-0	I-0	II-13W2	I-0	I-150	II-100
O267	3	I-36	I-36	II-59	I-36	I-36	II-64T2
A269	3	I-36G36	I-36G36	II-25	I-36G36	I-36G36	II-100
O271	3	I-C4	I-C4	II-13W2	I-0	I-150	II-100
A276	3	I-150	I-60	II-25	I-60	I-11T11	II-6T6
B283	3	I-150	I-60	II-25	I-60	I-11T11	II-13W2
A284	3	I-10T10	I-10T10	II-100	I-120T2	I-10T10	II-34
O287	3	I-11T11	I-11T11	II-100	I-120T2	I-11T11	II-34
O290	3	I-60	I-60	II-25	I-60	I-60	II-25
O291	3	I-10T10	I-72T4	II-25	I-60	I-60	II-64T2
O295	3	I-72T4	I-60	II-25	I-72T4	I-60	II-25
A295	3	I-150	I-60	II-25	I-60	I-11T11	II-25
O302	3	I-36	I-110	II-59	I-36	I-36	II-25
A302	3	I-36G36	I-110	II-59	I-36G36	I-36G36	II-25
O308	3	I-60	I-60	II-62F12	I-60	I-60	II-6T6
O309	3	I-150	I-20F12T8	II-20T4	I-47T2	I-60	II-6T6
O310	3	I-47T2	I-11T11	II-100	I-20F12T8	I-60	II-70T2
O312	3	I-11T11	I-60	II-100	I-60	I-11T11	II-70T2
A313	3	I-150	I-0	II-13W2	I-150	I-0	II-0
O319	3	I-150	I-60	II-25	I-60	I-11T11	II-13W2
O324	3	I-60	I-110	II-34	I-60	I-60	II-34
A324	3	I-10T10	I-10T10	II-0	I-150	I-120T2	II-34
O326	3	I-0	I-150	II-13W2	I-0	I-150	II-13W2
A324	3	I-10T10	I-10T10	II-0	I-150	I-120T2	II-34
O326	3	I-0	I-150	II-13W2	I-0	I-150	II-13W2
O330	3	I-150	I-120T2	II-34	I-10T10	I-10T10	II-6T6
O344	3	I-36	I-36	II-100	I-36A	I-36A	II-100
A344	3	I-72T4	I-60	II-25	I-121	I-60	II-6T6
B344	3	I-150	I-120T2	II-20T4G4	I-10T10	I-10T10	II-34
O348	3	I-60	I-60	II-20T4	I-60	I-110	II-34
A348	3	I-150	I-11T11	II-13W2	I-150	I-11T11	II-13W2
O353	3	I-11T11	I-11T11	II-25	I-150	I-150	II-6T6
O358	3	I-150	I-120T2	II-34	I-10T10	I-10T10	II-34
A358	3	I-36A	I-36A	II-25	I-150	I-11T11	II-100
B358	3	I-60	I-60	II-59	I-60	I-60	II-59
O362	3	I-11T11	I-11T11	II-6T6	I-150	I-150	II-34
A362	3	I-72T4	I-120T2	II-64T2	I-36	I-36	II-34
B370	3	I-150	I-60	II-100	I-24	I-11T11	II-13W2



Digit	Shell size	Insert arrangements					
		Cavity A	Cavity B	Cavity C	Cavity D	Cavity E	Cavity F
0382	3	I-150	I-60	II-100	I-24	I-11T11	II-25
0387	3	I-11T11	I-11T11	II-6T6	I-150	I-150	II-59
0392	3	I-11P11	I-11P11	II-100	I-20F12T8	I-150	II-100
0407	3	I-150	I-110	II-100	I-11T11	I-11T11	II-25
0421	3	I-150	I-120T2	II-70T2	I-11T11	I-11T11	II-59
A421	3	I-C4	I-C4	II-13W2	I-150	I-150	II-100
0426	3	I-11T11	I-150	II-100	I-10T10	I-121	II-34
0432	3	I-72T4	I-121	II-59	I-24	I-150	II-6T6
0434	3	I-150	I-150	II-0	I-121	I-0	II-13W2
0437	3	I-150	I-150	II-6T6	I-121	I-10T10	II-13W2
0444	3	I-150	I-121	II-13W2	I-150	I-10T10	II-0
A444	3	I-126	I-60	II-20T4A	I-150	I-60	II-20T4A
0450	3	I-150	I-150	II-6T6	I-121	I-10T10	II-13W2
0452	3	I-150	I-150	I-20T4G4	I-121	I-11T11	II-0
0463	3	I-150	I-0	II-13W2	I-150	I-150	II-0
0468	3	I-72T4	I-121	II-59	I-60	I-150	II-6T6
0469	3	I-150	I-120T2	II-0	I-126	I-11T11	II-62F12
0472	3	I-150	I-150	II-100	I-24	I-24	II-20T4
0490	3	I-150	I-11T11	II-59	I-150	I-120T2	II-0
0492	3	I-11T11	I-150	II-100	I-10T10	I-10T10	II-34
0494	3	I-121	I-120T2	II-6T6	I-121	I-120T2	II-6T6
0496	3	I-121	I-121	II-6T6	I-121	I-121	II-6T6
0510	3	I-121	I-121	II-13W2	I-121	I-121	II-13W2
0514	3	I-150	I-150	II-64T2	I-120T2	I-24	II-6T6
0516	3	I-150	I-150	II-84	I-121	I-11T11	II-0
0530	3	I-120T2	I-120T2	II-25	I-120T2	I-120T2	II-25
0537	3	I-150	I-150	II-100	I-121	I-10T10	II-6T6
0547	3	I-60	I-150	II-13W2	I-150	I-150	II-20T4
0550	3	I-150	I-150	II-100	I-150	I-0	II-0
0552	3	I-121	I-121	II-34	I-121	I-121	II-34
0554	3	I-121	I-150	II-6T6	I-121	I-150	II-6T6
0563	3	I-0	I-150	II-100	I-150	I-150	II-13W2
0565	3	I-150	I-11T11	4 MT	I-150	I-150	II-100
0568	3	I-60	I-150	II-34	I-150	I-150	II-20T4
0577	3	I-20F12T8	I-150	II-85	I-150	I-72T4	II-100
0579	3	I-150	I-150	II-64T2	I-121	I-60	II-34
0600	3	I-150	I-150	II-0	I-150	I-150	II-0
0601	3	I-150	I-150	II-20T4	I-150	I-121	II-6T6
0608	3	I-120T2	I-150	II-34	I-120T2	I-150	II-34
0612	3	I-150	I-150	II-6T6	I-150	I-150	II-6T6
0613	3	I-150	I-150	II-13W2	I-150	I-150	II-0
A613	3	I-150	I-150	II-0	I-150	I-150	II-13W2
0615	3	I-150	I-60	II-100	I-150	I-150	II-25
0620	3	I-150	I-60	II-100	I-150	I-60	II-100



Digit	Shell size	Insert arrangements					
		Cavity A	Cavity B	Cavity C	Cavity D	Cavity E	Cavity F
A620	3	I-150	I-150	II-100	I-60	I-60	II-100
0621	3	I-150	I-11T11	II-100	I-150	I-110	II-100
0626	3	I-150	I-150	II-13W2	I-150	I-150	II-13W2
0630	3	I-150	I-150	II-6T6	I-150	I-150	II-20T4
A630	3	I-150	I-150	II-6T6	I-150	I-150	II-20T4A
B630	3	I-150	I-150	II-25	I-150	I-150	II-20T4A
0632	3	I-150	I-11T11	II-100	I-150	I-121	II-100
0648	3	I-150	I-150	II-20T4	I-150	I-150	II-20T4G4
A648	3	I-150	I-150	II-20T4A	I-150	I-150	II-20T4A
B648	3	I-60	I-150	II-100	I-150	I-88	II-100
0668	3	I-150	I-150	II-34	I-150	I-150	II-34
0695	3	I-150	I-150	II-20T4	I-150	I-121	II-100
0698	3	I-150	I-150	II-64T2	I-150	I-150	II-34
0713	3	I-150	I-150	II-100	I-150	I-150	II-13W2
A713	3	I-150	I-150	II-13W2	I-150	I-150	II-100
0720	3	I-150	I-150	II-100	I-150	I-150	II-20T4G4
0724	3	I-150	I-150	II-100	I-150	I-150	II-20T4
A724	3	I-150	I-150	II-100	I-150	I-150	II-20T4A
0734	3	I-150	I-150	II-100	I-150	I-150	II-34
0742	3	I-121	I-150	II-100	I-121	I-150	II-100
0785	3	I-150	I-150	II-100	I-150	I-150	II-85
A785	3	I-150	I-150	II-85	I-150	I-150	II-100
0800	3	I-150	I-150	II-100	I-150	I-150	II-100



RF contact

The SB6 series products can install #8 RF contacts at the #8 hole position to achieve RF transmission. The frequency range for standard #8 RF contact is 0 – 500 MHz.

Ordering information

Basic series	S7-RF	2	S	-8	B
Contact type:					
Omit = ordinary single coaxial contact					
2 = Shielded twisted pair contacts capable of transmitting 1553B signals (triax)					
Contact type:					
P = pin (for Equipment receptacle)					
S = socket (for Rack plug)					
8 = Contact size					
Contact Mounting & Release:					
Omit = crimped					
B = PC tail contact (only applicable to pins)					

The SB6 series connectors are mainly used on chassis and cabinets. Due to the inevitable large gap between the cabinet and the installation rack, the reference planes of the coaxial contact pins and sockets cannot be fully inserted in place. Moreover, when multiple pins and sockets are inserted, the insertion surfaces of each pin and socket may not be completely consistent, resulting in impedance discontinuity in the RF signal transmission channel, it will directly affect the voltage standing wave ratio and transmission loss in the high-frequency range, causing the equipment to be unable to work properly. To solve the above problems, our company has designed coaxial contacts with axial floating, radial positioning, and sealing.



High frequency contacts

Impedance: 50 Ω
 Temperature range: -65°C ~ +150°C
 Maximum operating frequency: 18 GHz
 Insertion loss: ≤ 0.3 dB
 Connecting stable phase low loss coaxial cables

Ordering information

Basic series	S7-RF	-S	-#8	1801
Contact type:				
P = pin (for Equipment receptacle)				
S = socket (for Rack plug)				
Contact size: #1, #5, #8 (consultation needed)				
Matching cable code: 086, 141, 1801, 3449, 32055				

Cable code	Cable type	Frequency of cable, max (GHz)
141	SFT-50-3-1, 670-141, 670-141SXE	18
1801	IW1801	34
3449	CXN3449	18

Differential contacts

The #8 hole position of the SB6 series products can be equipped with #8 differential contact components for differential signal transmission (such as AFDX signal, DVI signal, Gigabit Ethernet signal, ARINC429 signal)

Ordering information

Basic series	CF	82/	211	-03	-B2
Contact type:					
81 = pin (for Equipment receptacle)					
82 = socket (for Rack plug)					
Contact type:					
211 = differential twinaxial contact					
411 = quadraxial contact					
231 = differential twinaxial PC tail contact, (pin for Equipment receptacle only)					
431 = quadraxial contact PC tail contact, (pin for Equipment receptacle only)					
03 = contacts for connectors SB series					
PC tail contacts lengths (pin for Equipment receptacle only):					
Omit = crimped					
B1 = 3.8 mm					
B2 = 7.3 mm					
B3 = 9.5 mm					
B4 = 12.7 mm					

Arinc 801 Fiber Optic Termini

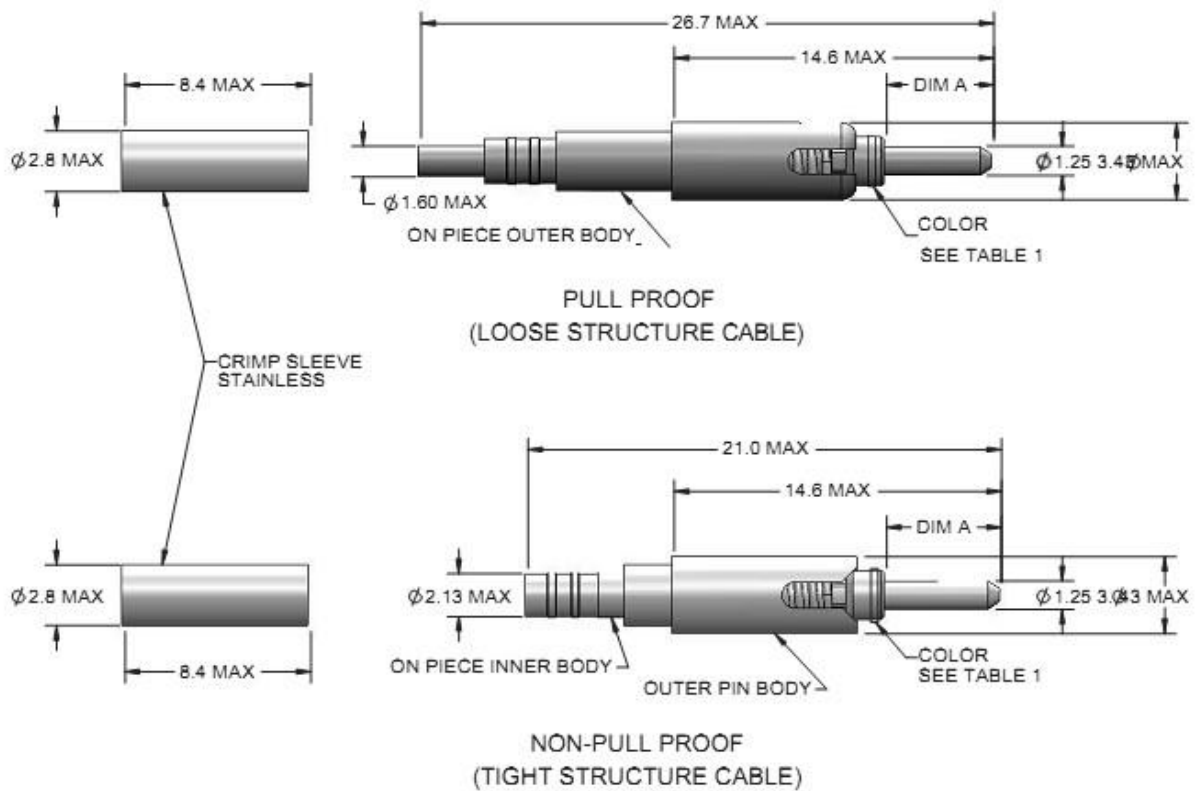

Fiber Optic Termini A8T. Ordering information

Basic series	A8T	-M	2
Fiber type:			
M = Multimode fiber 62.5/125 μm			
MI = Multimode fiber 50/12 5 μm			
MIV = Multimode fiber high speed OM3 50/12 5 μm			
Cable diameter:			
0.9 = \varnothing 900 μm fiber cable			
2 = \varnothing 2 mm fiber cable			

Fiber Optic Termini E8T. Ordering information

Basic series	E8T	-M	2
Fiber type:			
S = Singlemode fiber 9/125 μm			
M = Multimode fiber 62.5/125 μm			
MI = Multimode fiber 50/12 5 μm			
MIV = Multimode fiber high speed OM3 50/12 5 μm			
Cable diameter:			
0.9 = \varnothing 900 μm fiber cable			
2 = \varnothing 2 mm fiber cable			

Fiber Optic Harnesses & Patchcord

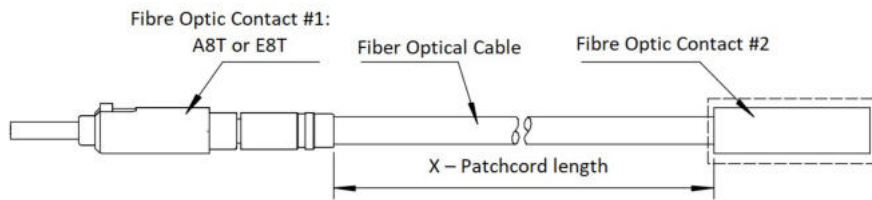

Fibre Optic Contact #1 – A8T. Ordering information

Basic series	A8T	-FC	-M	2	L4
Fibre Optic Contact #2: FC, AFC, SC, LC, ST etc					
Fiber type:					
M = Multimode fiber 62.5/125 μm					
MI = Multimode fiber 50/125 μm					
MIV = Multimode fiber high speed OM3 50/125 μm					
Cable diameter:					
0.9 = \varnothing 900 μm fiber cable					
2 = \varnothing 2 mm fiber cable					
Patchcord length:					
LX = means cable length is X m, customers should order with the cable length					

Fibre Optic Contact #1 – E8T. Ordering information

Basic series	E8T	-FC	-	M	2	K	L4
Fibre Optic Contact #2: FC, JFC, SC, LC, ST etc							
Wave length:							
Omit = Singlemode, Wave length 1310 nm, & Multimode, Wave length 850 nm							
13 = Multimode, Wave length 1300 nm							
15 = Singlemode, Wave length 1550 nm							
Fibre type:							
S = Singlemode fiber 9/125 μm , G652D							
S = Singlemode fiber 9/125 μm , G657A2							
FS = Singlemode fiber 9/125 μm , G652D, EFTF cable							
M = Multimode fiber 62.5/125 μm							
MI = Multimode fiber 50/125 μm							
MIV = Multimode fiber high speed OM3 50/125 μm							
FM = Multimode fiber 62.5/125 μm , EFTF cable							
FMIV = Multimode fiber high speed OM3 50/125 μm , EFTF cable							
Cable diameter:							
0.9 = fiber cable \varnothing 900 μm							
2 = fiber cable \varnothing 2 mm							
Structure outer jacket:							
Omit = unarmored cable							
K = armored cable							
Patchcord length:							
LX = means cable length is X m, customers should order with the cable length							

Dimensions

Shell Size 1

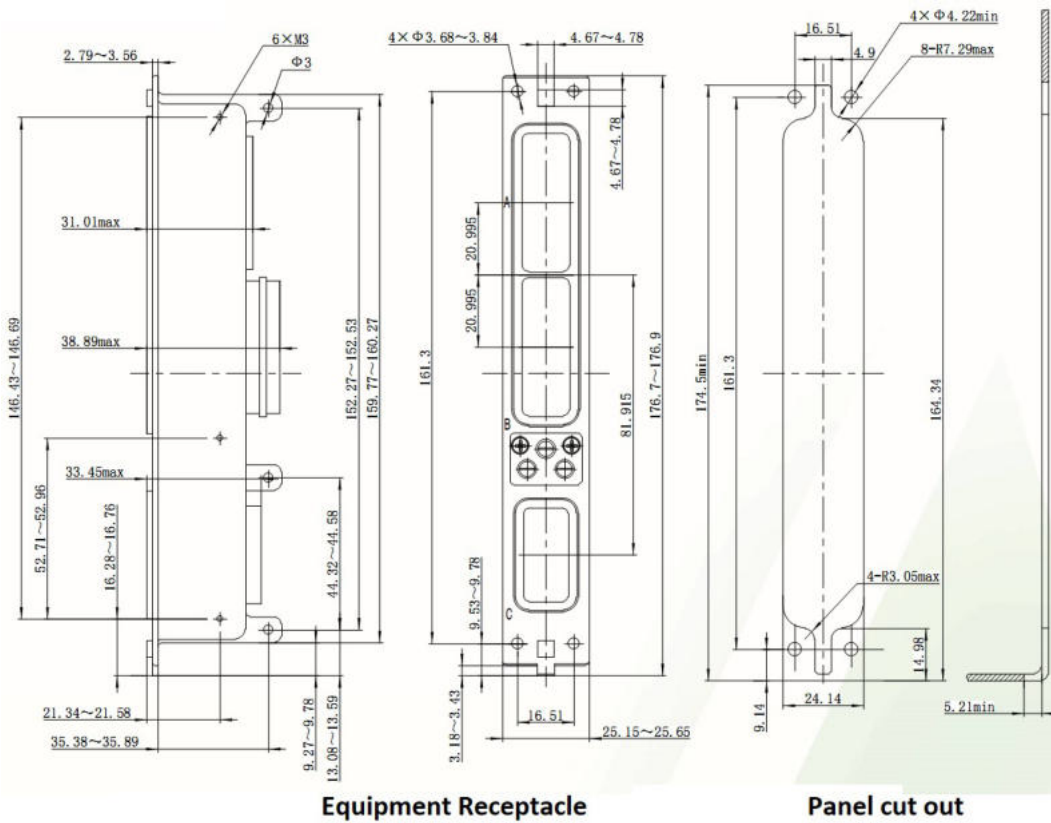
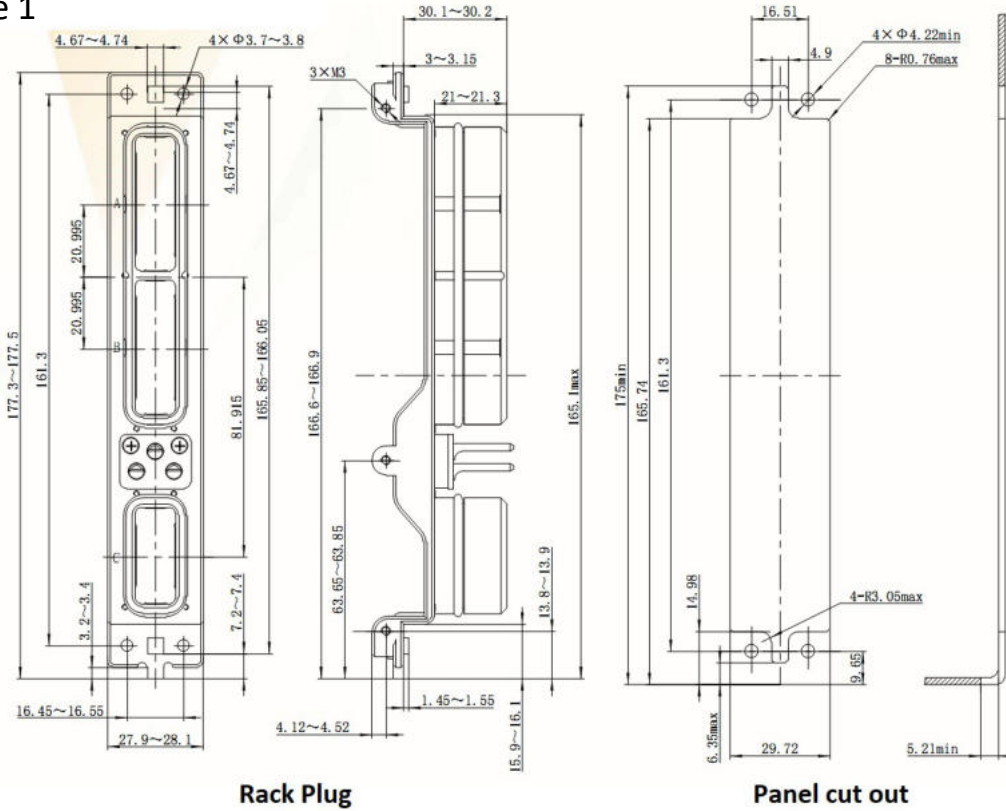

Dimensions

Shell Size 2

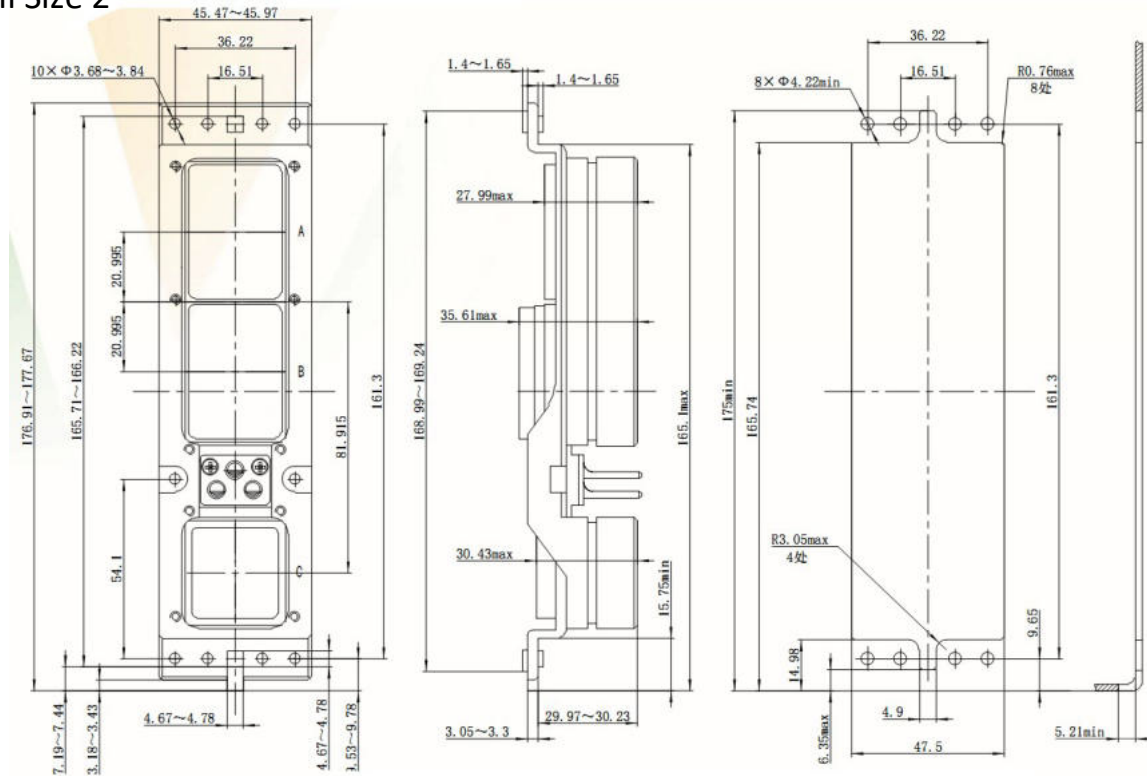

Rack Plug

Panel cut out

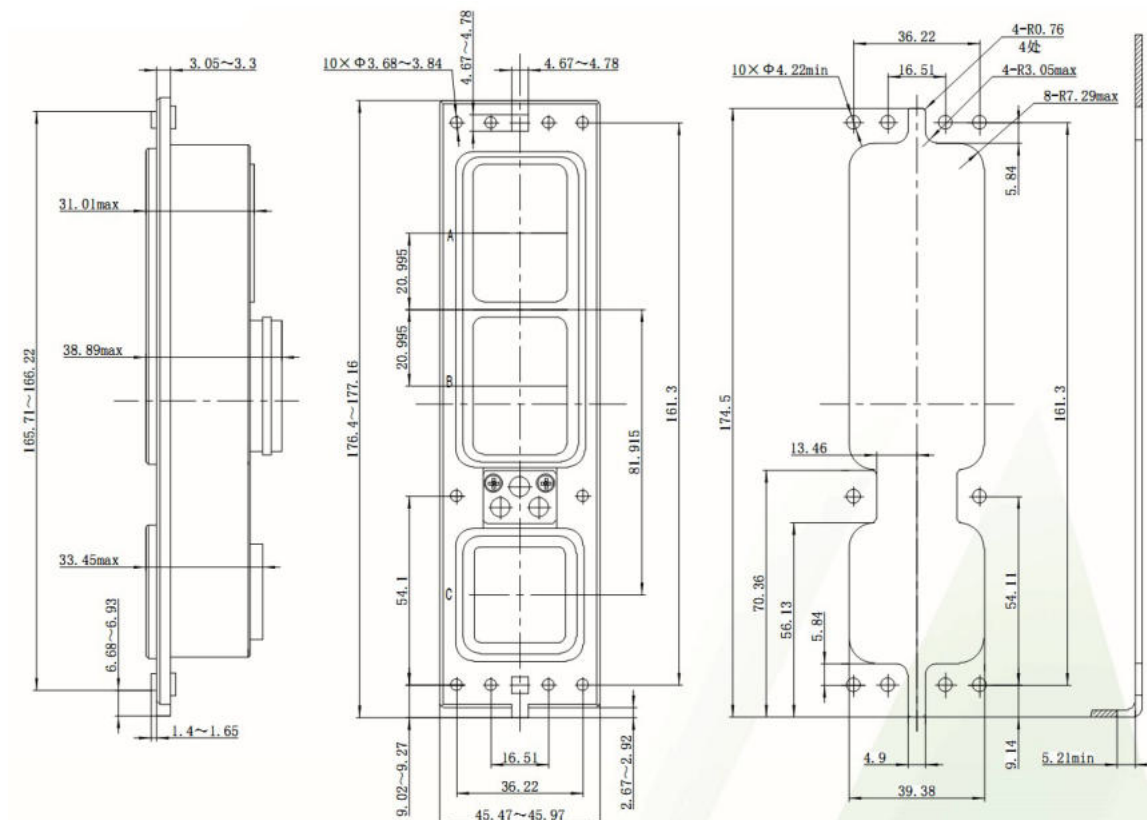

Equipment Receptacle

Panel cut out

Dimensions

Shell Size 3

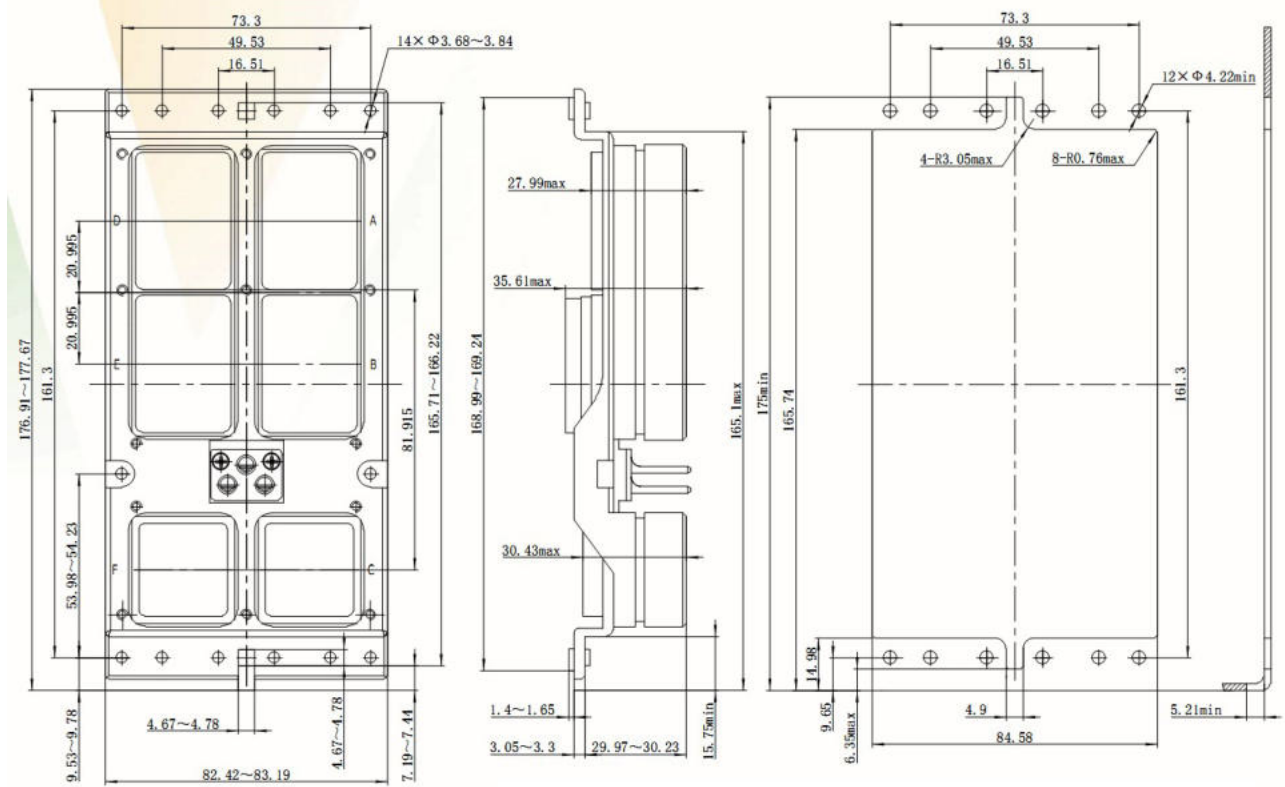

Rack Plug

Panel cut out

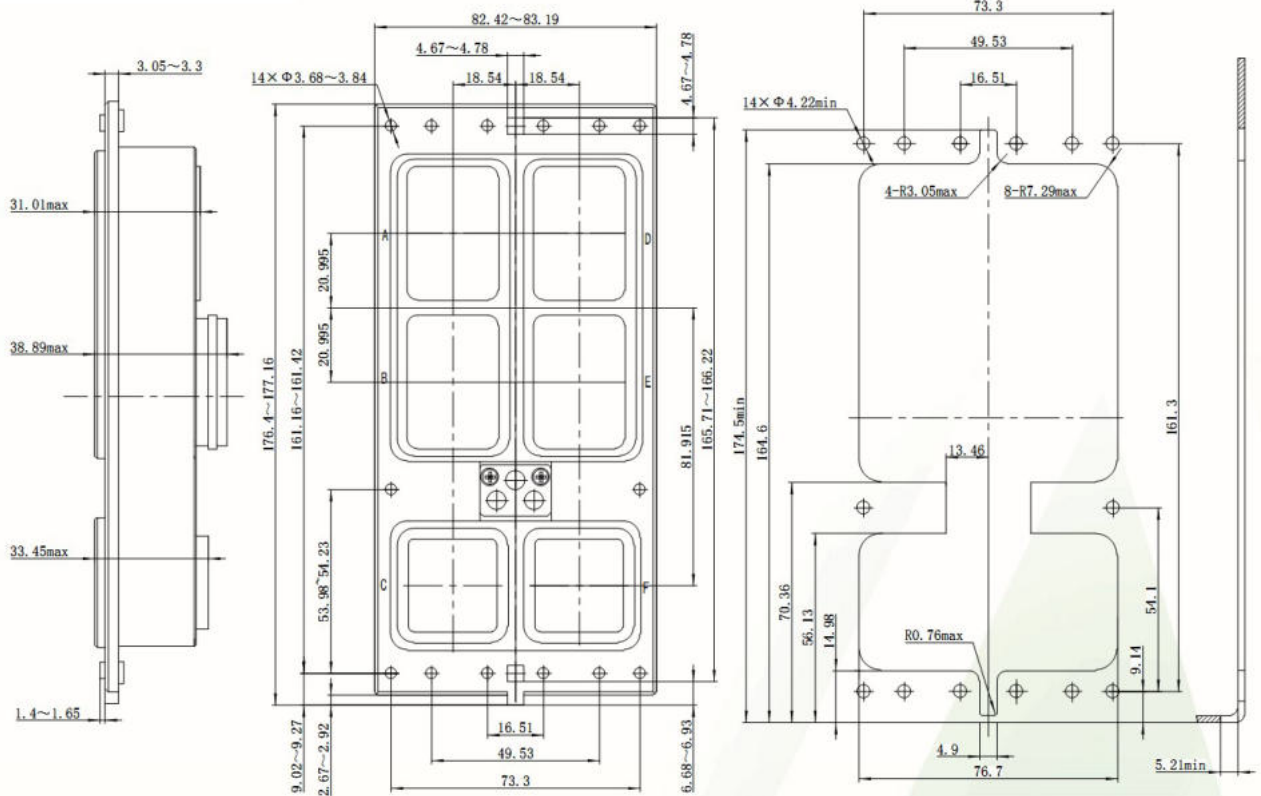

Equipment Receptacle

Panel cut out

Floating installation

The SB6 series floating products are divided into two types, one is the floating product with a floating amount of ± 0.25 mm, the other is the floating product with a floating amount of ± 0.75 mm. Both of them are floating by installing a floating sleeve on the plug, which ensures the smooth alignment of the plug socket after installation. The following figure shows the floating installation of the SB6 series plug housing. Note that only four to six mounting holes can be used in floating mounting to reduce friction between the floating sleeve and the panel for floating function. (Note: ± 0.25 mm floating product should have a distance between two mounting panels minus the thickness of floating sleeve 1.5 The distance between two panels is $11.4 - 11.8$ ± 0.75 mm floating product should have a distance between two mounting panels of $12.75 - 13$ mm.)

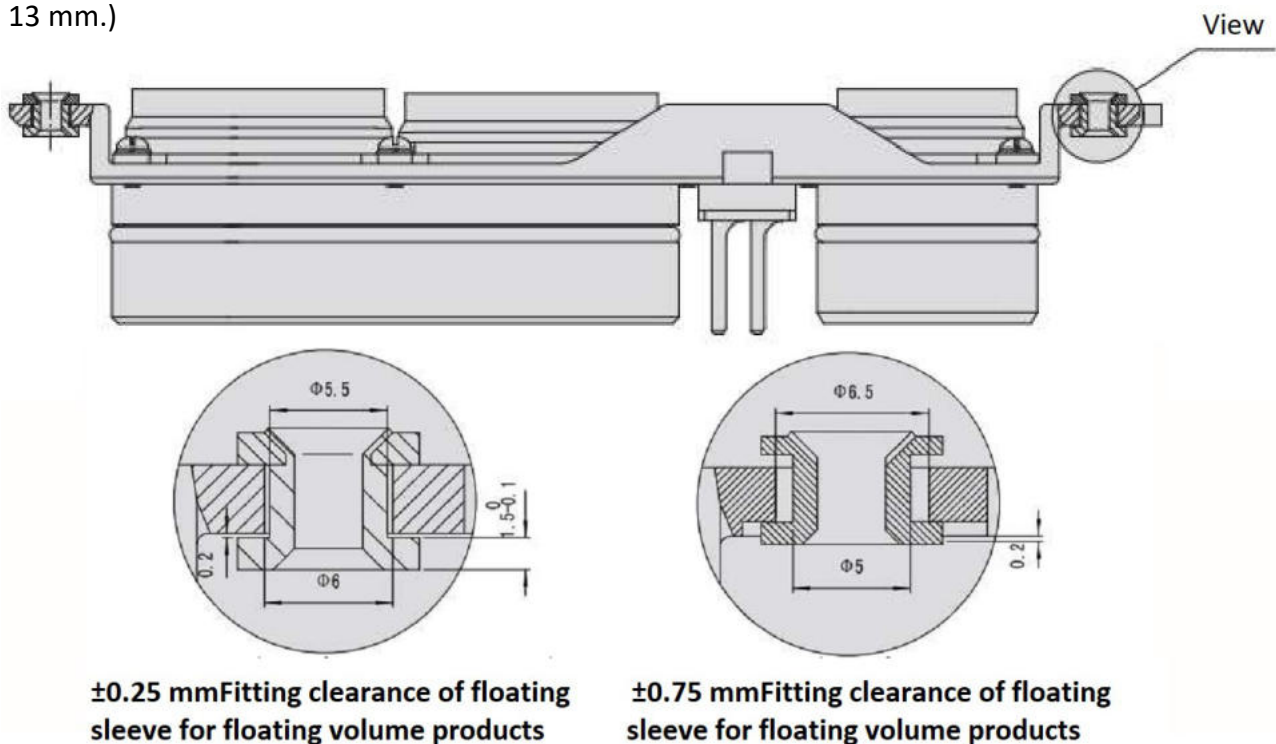

Polarizing keys

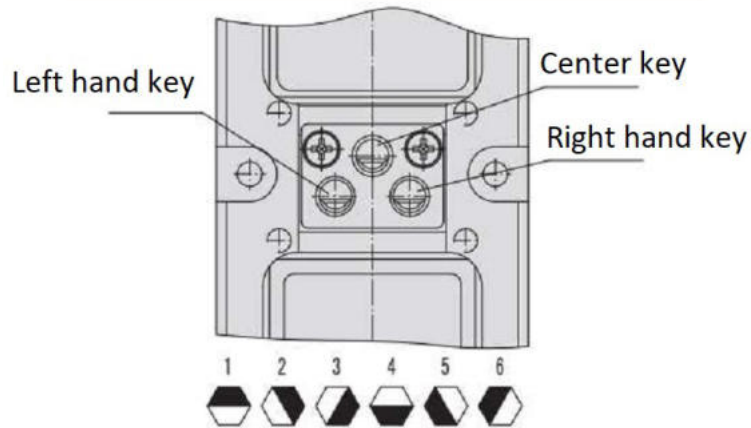

The blackened part represents the extension part of the guide pin or the projection part of the guide sleeve (the socket surface)

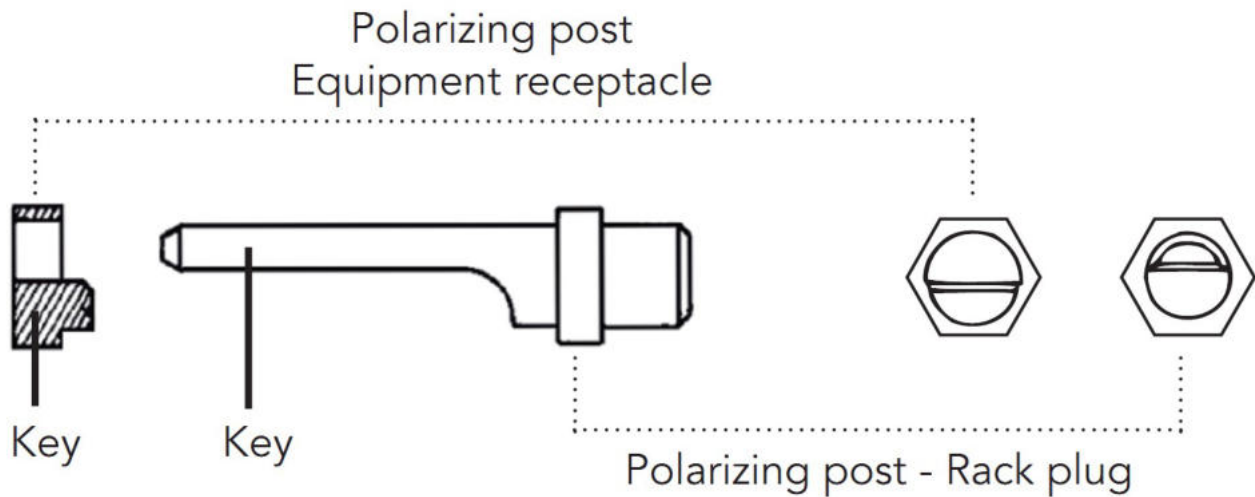



Polarization code

Code	Receptacle			Plug		
	Left Key	Center Key	Right Key	Left Key	Center Key	Right Key
00	–	–	–	–	–	–
01	4	4	4	1	1	1
02	4	4	3	2	1	1
03	4	4	2	3	1	1
04	4	4	1	4	1	1
05	4	4	6	5	1	1
06	4	4	5	6	1	1
07	5	4	4	1	1	6
08	5	4	3	2	1	6
09	5	4	2	3	1	6
10	5	4	1	4	1	6
11	5	4	6	5	1	6
12	5	4	5	6	1	6
13	6	4	4	1	1	5
14	6	4	3	2	1	5
15	6	4	2	3	1	5
16	6	4	1	4	1	5
17	6	4	6	5	1	5
18	6	4	5	6	1	5
19	1	4	4	1	1	4
20	1	4	3	2	1	4
21	1	4	2	3	1	4
22	1	4	1	4	1	4
23	1	4	6	5	1	4
24	1	4	5	6	1	4
25	2	4	4	1	1	3
26	2	4	3	2	1	3
27	2	4	2	3	1	3
28	2	4	1	4	1	3
29	2	4	6	5	1	3
30	2	4	5	6	1	3
31	3	4	4	1	1	2
32	3	4	3	2	1	2
33	3	4	2	3	1	2
34	3	4	1	4	1	2
35	3	4	6	5	1	2
36	3	4	5	6	1	2
37	4	3	4	1	2	1
38	4	3	3	2	2	1



Code	Receptacle			Plug		
	Left Key	Center Key	Right Key	Left Key	Center Key	Right Key
39	4	3	2	3	2	1
40	4	3	1	4	2	1
41	4	3	6	5	2	1
42	4	3	5	6	2	1
43	5	3	4	1	2	6
44	5	3	3	2	2	6
45	5	3	2	3	2	6
46	5	3	1	4	2	6
47	5	3	6	5	2	6
48	5	3	5	6	2	6
49	6	3	4	1	2	5
50	6	3	3	2	2	5
51	6	3	2	3	2	5
52	6	3	1	4	2	5
53	6	3	6	5	2	5
54	6	3	5	6	2	5
55	1	3	4	1	2	4
56	1	3	3	2	2	4
57	1	3	2	3	2	4
58	1	3	1	4	2	4
59	1	3	6	5	2	4
60	1	3	5	6	2	4
61	2	3	4	1	2	3
62	2	3	3	2	2	3
63	2	3	2	3	2	3
64	2	3	1	4	2	3
65	2	3	6	5	2	3
66	2	3	5	6	2	3
67	3	3	4	1	2	2
68	3	3	3	2	2	2
69	3	3	2	3	2	2
70	3	3	1	4	2	2
71	3	3	6	5	2	2
72	3	3	5	6	2	2
73	4	2	4	1	3	1
74	4	2	3	2	3	1
75	4	2	2	3	3	1
76	4	2	1	4	3	1
77	4	2	6	5	3	1
78	4	2	5	6	3	1
79	5	2	4	1	3	6
80	5	2	3	2	3	6



Code	Receptacle			Plug		
	Left Key	Center Key	Right Key	Left Key	Center Key	Right Key
81	5	2	2	3	3	6
82	5	2	1	4	3	6
83	5	2	6	5	3	6
84	5	2	5	6	3	6
85	6	2	4	1	3	5
86	6	2	3	2	3	5
87	6	2	2	3	3	5
88	6	2	1	4	3	5
89	6	2	6	5	3	5
90	6	2	5	6	3	5
91	1	2	4	1	3	4
92	1	2	3	2	3	4
93	1	2	2	3	3	4
94	1	2	1	4	3	4
95	1	2	6	5	3	4
96	1	2	5	6	3	4
97	2	2	4	1	3	3
98	2	2	3	2	3	3
99	2	2	2	3	3	3

Coordinates for straight PC tail terminations Viewed from front face of male insulator

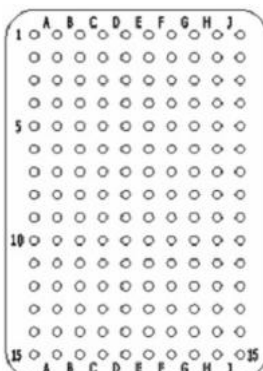
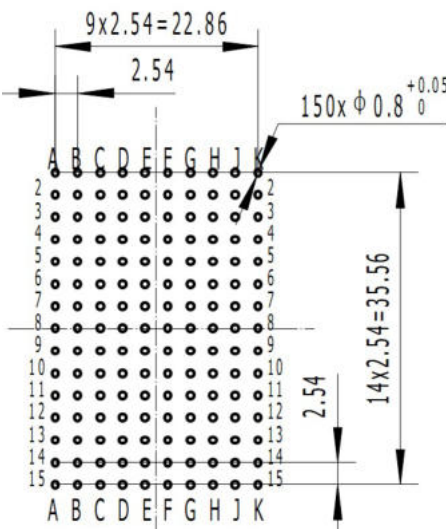
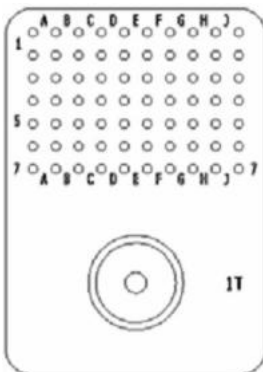
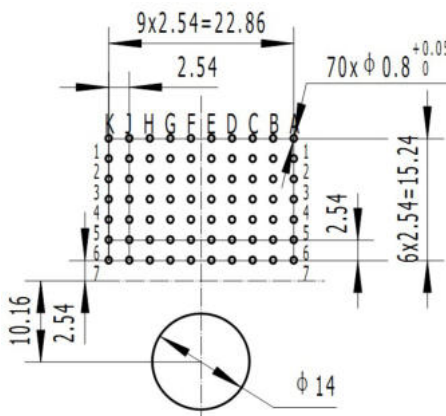
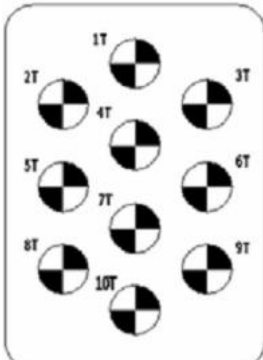
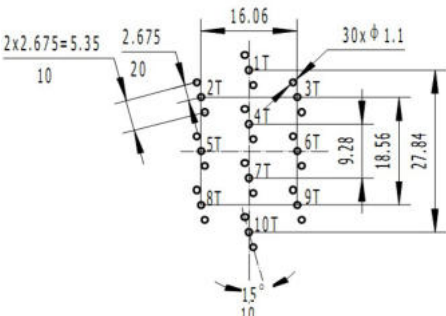
Insulator code	Contact type/quantity	Insert arrangement (Front face view of male insert)	Co-ordinates for straight spill terminaison
Insert Arrangements. Shell size 2 & 3. Cavity A, B, D & E			
I-150	150 – #22		
I-70C1	70 – #22 1 – #1		
I-10T10	10 – #8		

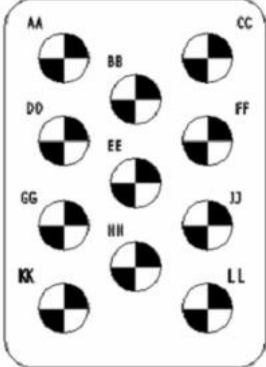
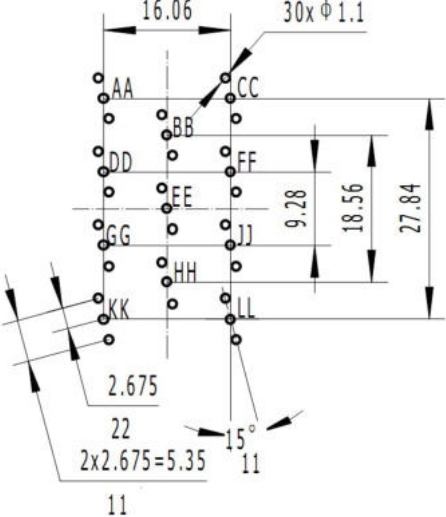
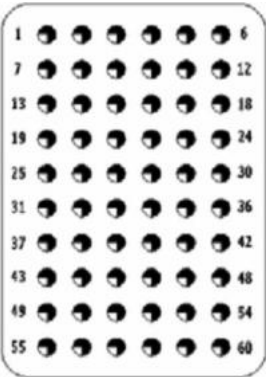
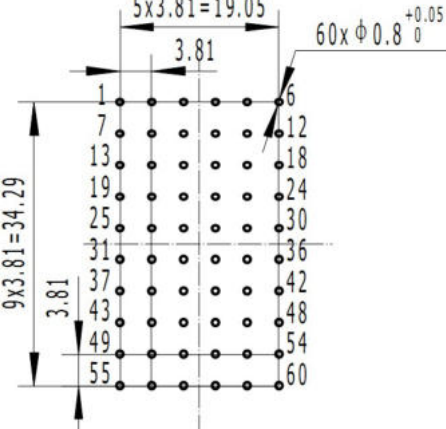
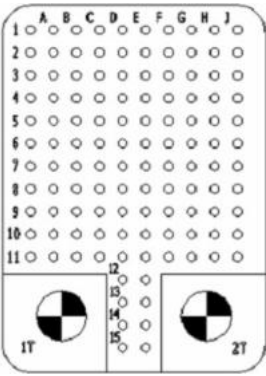
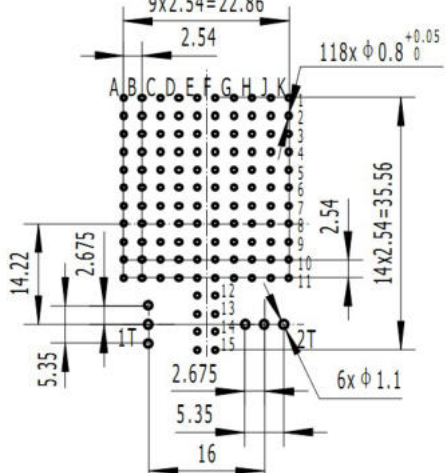
Insulator code	Contact type/quantity	Insert arrangement (Front face view of male insert)	Co-ordinates for straight spill terminaison
Insert Arrangements. Shell size 2 & 3. Cavity A, B, D & E			
I-11T11	11 – #8		
I-60	60 – #20		
I-120T2	118 – #22 2 – #8		

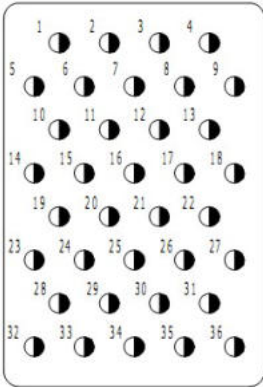
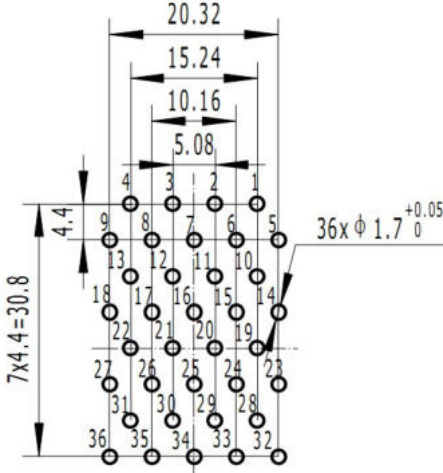
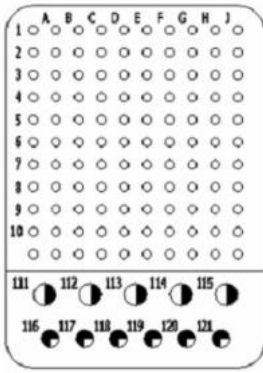
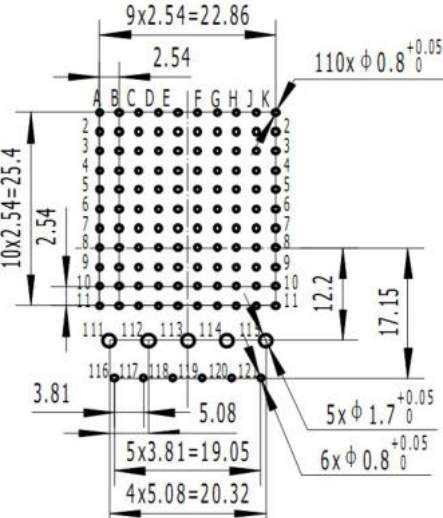
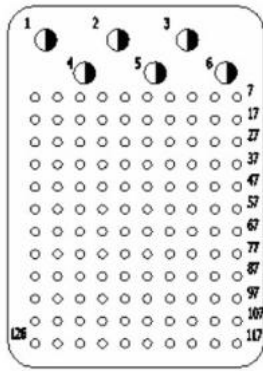
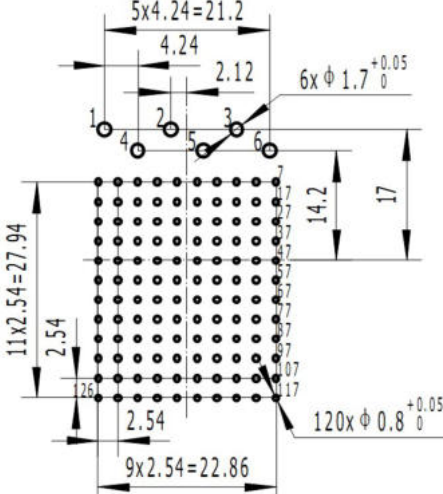
Insulator code	Contact type/quantity	Insert arrangement (Front face view of male insert)	Co-ordinates for straight spill terminaison
Insert Arrangements. Shell size 2 & 3. Cavity A, B, D & E			
I-36A	36 – #16		
I-121	110 – #22 6 – #20 5 – #16		
I-126	120 – #22 6 – #16		

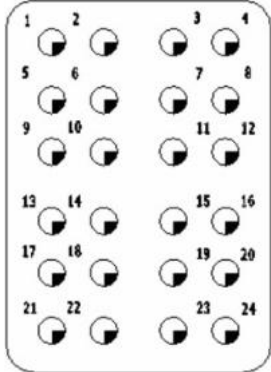
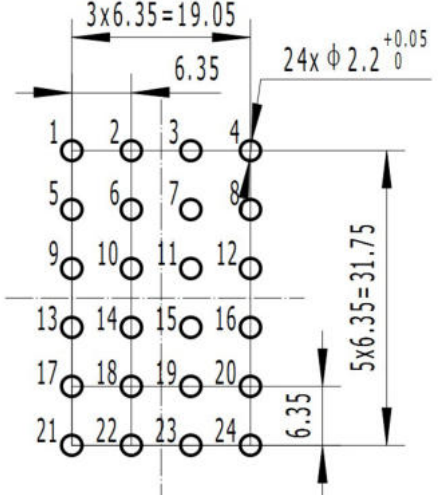
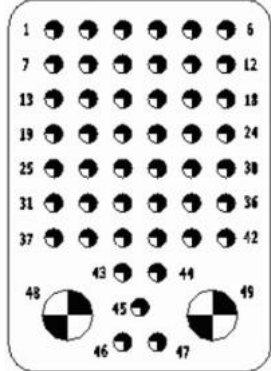
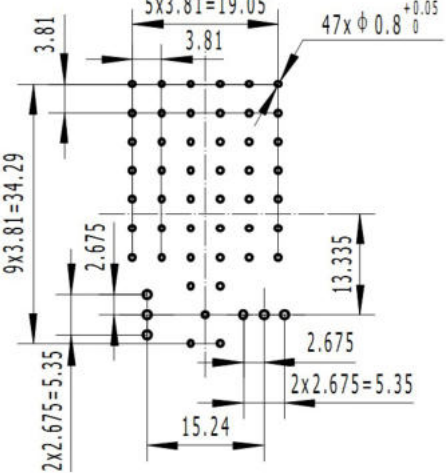
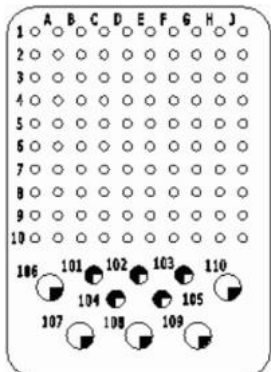
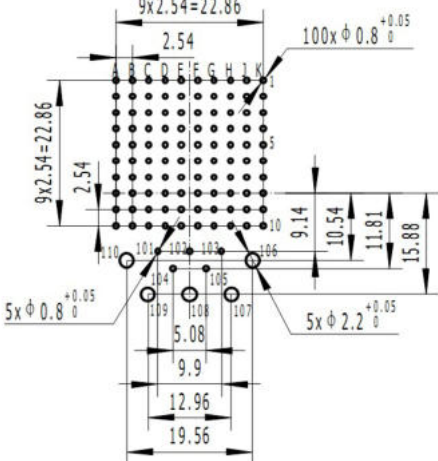
Insulator code	Contact type/quantity	Insert arrangement (Front face view of male insert)	Co-ordinates for straight spill terminaison
Insert Arrangements. Shell size 2 & 3. Cavity A, B, D & E			
I-24	24 – #12		
I-47T2	47 – #20 2 – #8		
I-110	100 – #22 5 – #20 5 – #12		

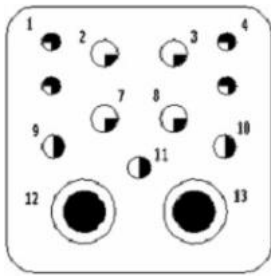
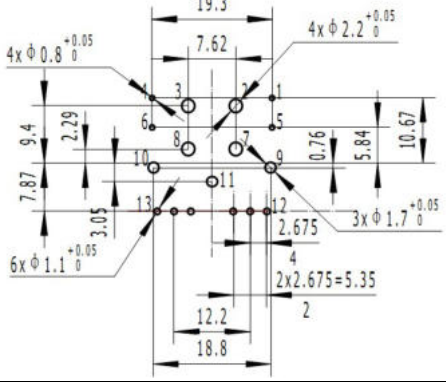
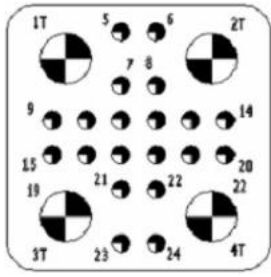
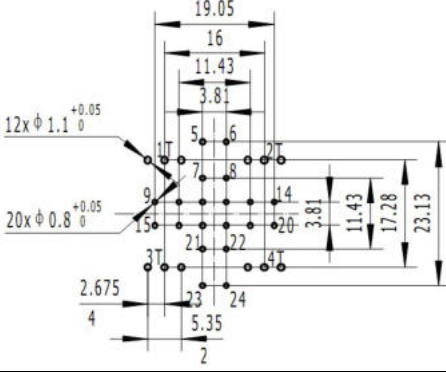
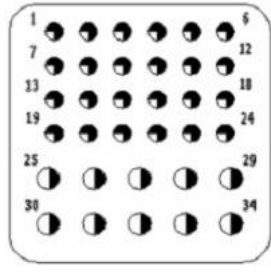
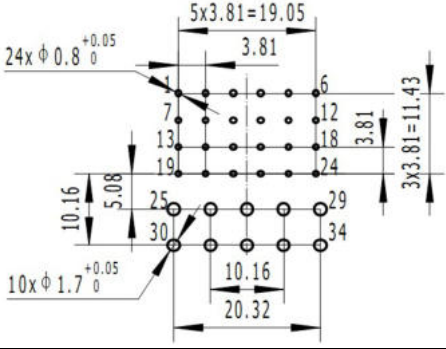
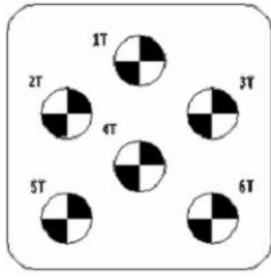
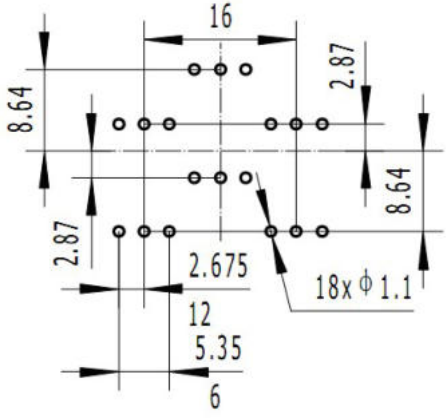
Insulator code	Contact type/quantity	Insert arrangement (Front face view of male insert)	Co-ordinates for straight spill terminaison
Insert Arrangements. Shell size 2 & 3. Cavity C & F			
II-13W2	4 – #20 3 – #16 4 – #12 2 – #5		
II-20T4	20 – #20 4 – #8		
II-34	24 – #20 10 – #16		
II-6T6	6 – #8		

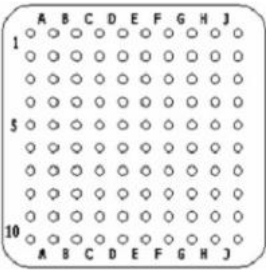
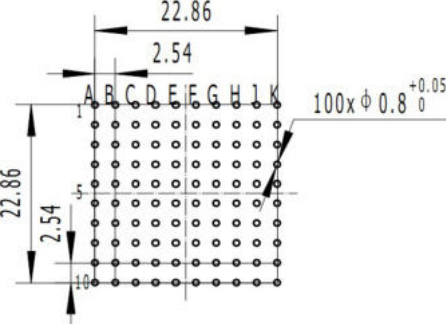
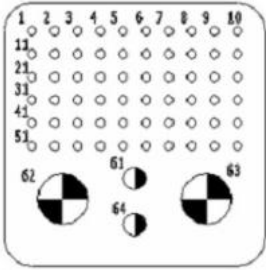
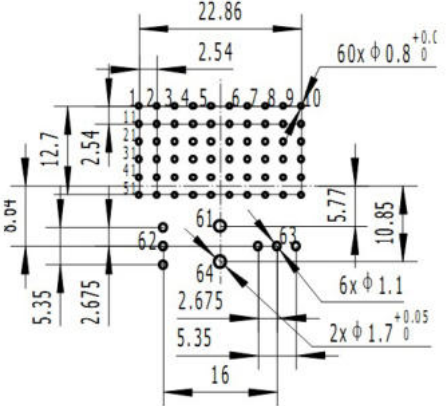
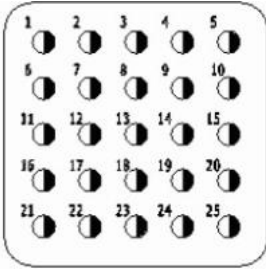
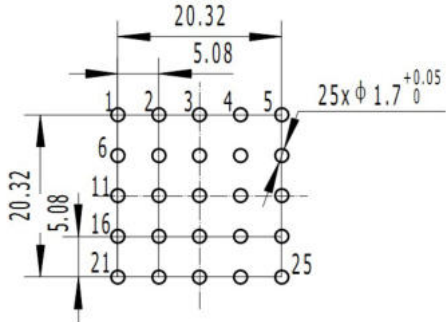
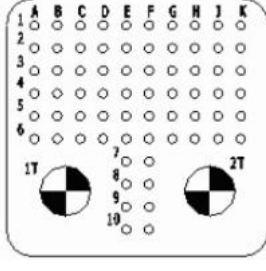
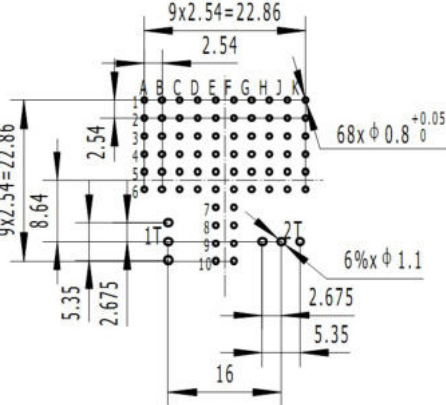
Insulator code	Contact type/quantity	Insert arrangement (Front face view of male insert)	Co-ordinates for straight spill terminaison
Insert Arrangements. Shell size 2 & 3. Cavity C & F			
II-100	100 – #22		
6-II-64T2	60 – #22 2 – #16 2 – #8		
II-25	25 – #16		
II-70T2	68 – #22 2 – #8		

Insulator code	Contact type/quantity	Insert arrangement (Front face view of male insert)	Co-ordinates for straight spill terminaison
Insert Arrangements. Shell size 2 & 3. Cavity C & F			
II-85	80 – #22 4 – #20 1 – #16		
II-84	80 – #22 4 – #20		
II-59	50 – #22 5 – #16 4 – #12		
		For Cavity A, B, D & E	For Cavity C & F

Examples

SB6N*2ZPB*B122 with CF81/431-03-B*

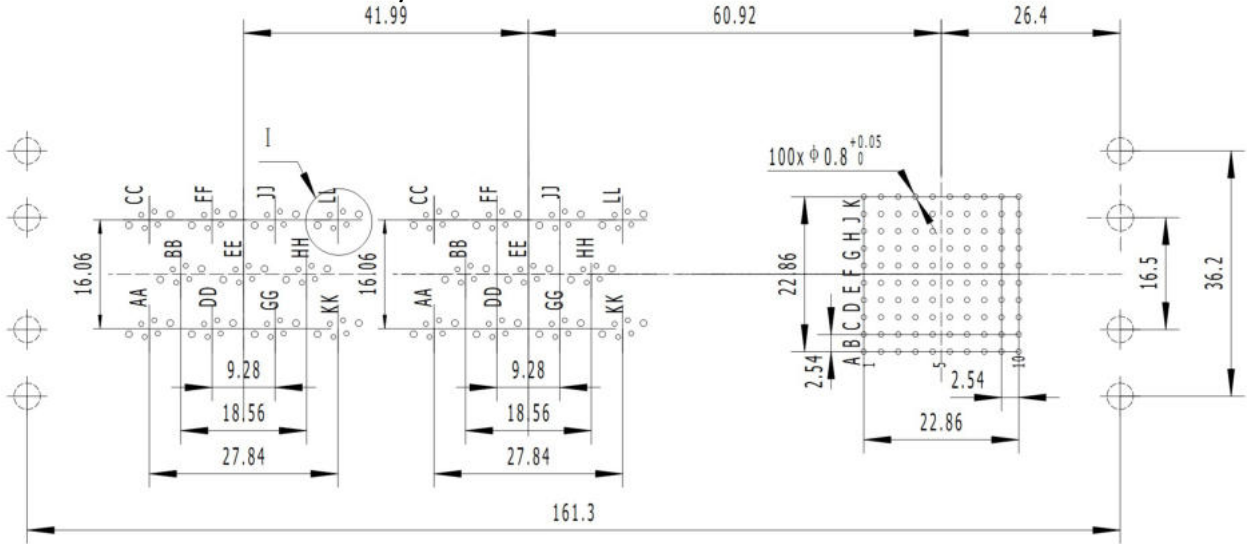

SB6N*2ZPB*B370 with CF81/431-03-B*

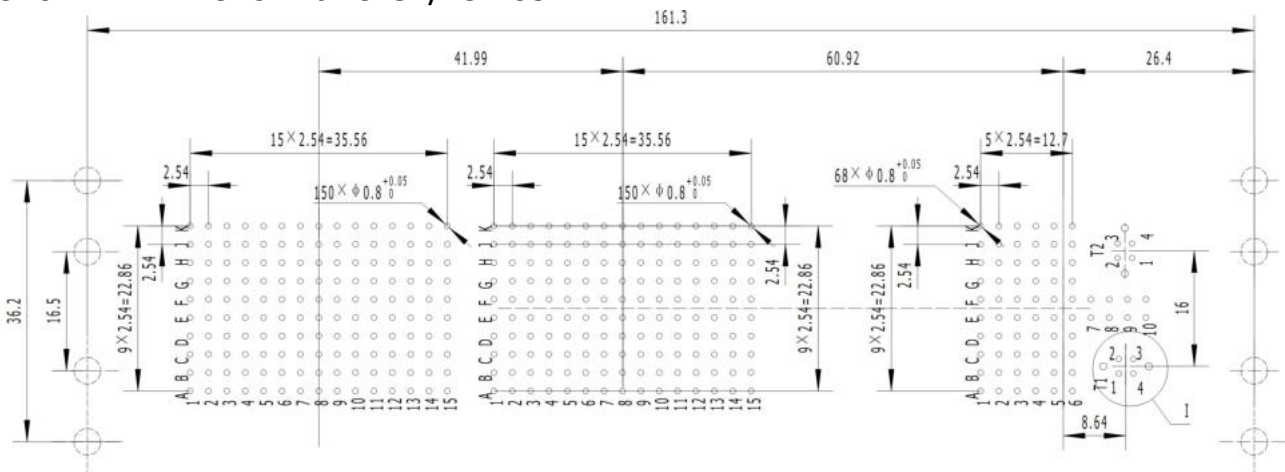

SB6N*1ZPB*0125 with S7-RF-P-#5-3449

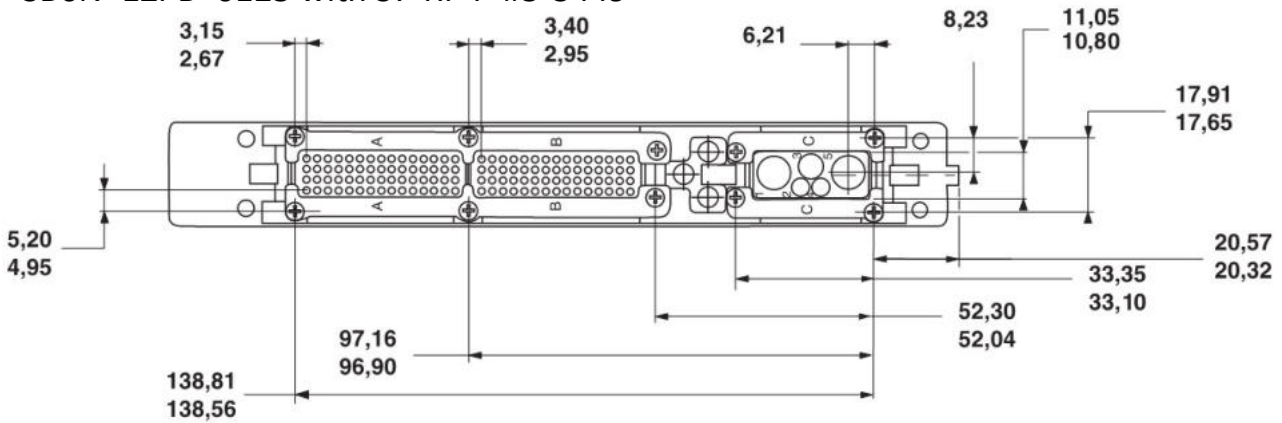

Examples

SB6N*2ZPB*0313 with S7-RF-P-#5-3449

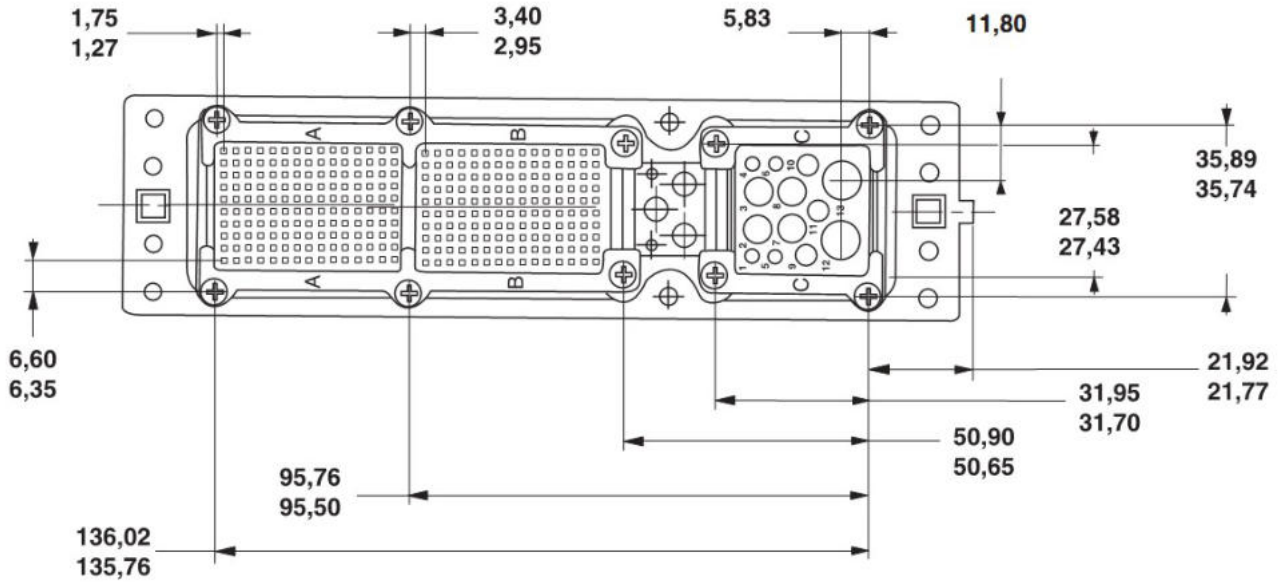

SB6N*3ZPB*0626 with S7-RF-P-#5-3449

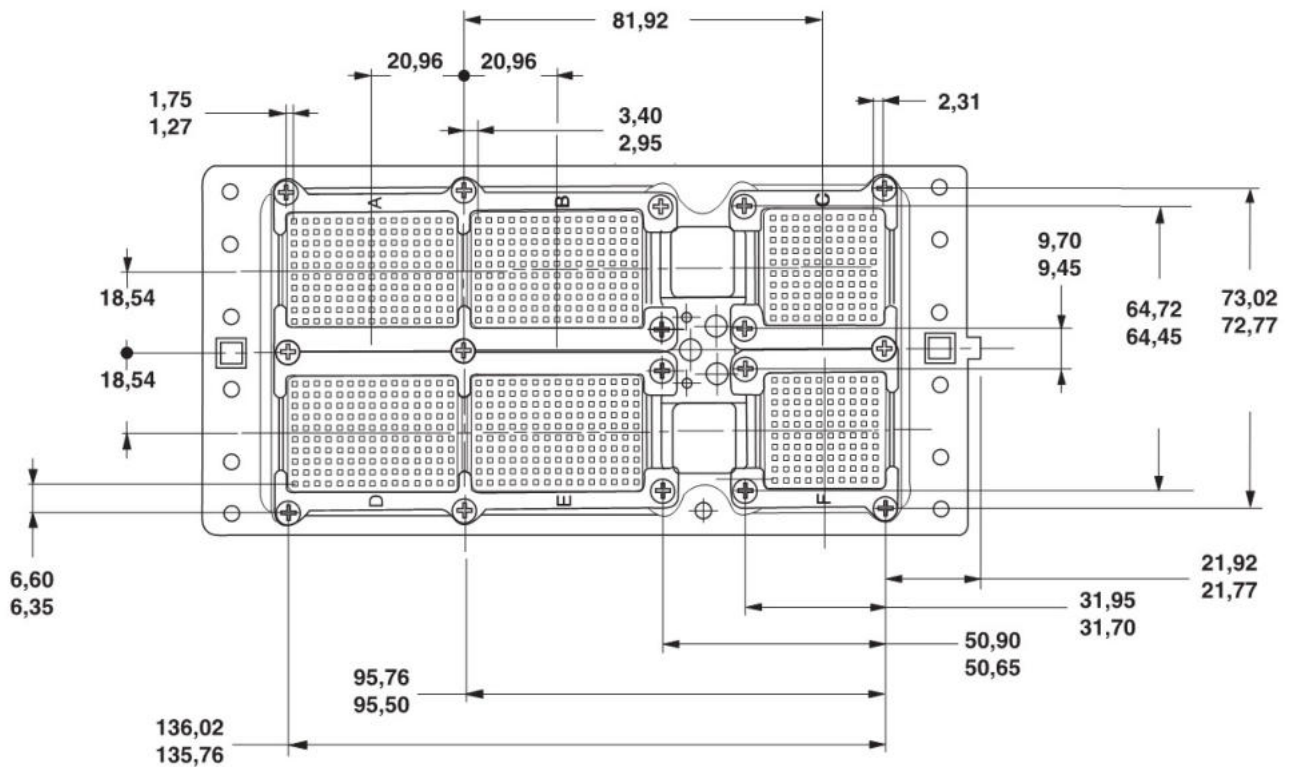

Backshells for ARINC 600

EMI shielding

Fix the cable

Nice environmental performance

Shell: aluminum alloy/cadmium plating or nickel plating

Shock: 11 ms half sine, acceleration 50 g

Function vibration: 15 ~ 2000 Hz, power chart density 0.126 g²/Hz, lasting 6 h

Endurance vibration: 15 ~ 2000 Hz, power chart density 0.201 g²/Hz, lasting 7.5 h

Salt spray: 500 h (cadmium plating); 96 h (nickel plating)

Backshells size 1. Ordering information

Basic series	SB6	F	-1	FJ	1	A
Plating:						
F = Electroless nickel						
W = cadmium						
Shell Size = 1						
Product type = Backshell for ARINC600						
Backshell type:						
1 = Backshell for cavity A & B						
2 = Backshell for cavity C						
Entry position:						
A = straight lead-out						

NOTE

- In Backshell mounting, remove the connector original screws, and change them into the small crimping metal plate and long screw, which are matched with the accessory. And then fix Backshell with the shell. (See the below picture);
- This Backshell realizes 360°shielding, and can clamp the cable. Backshell is ordered separately;
- For S6-1 series product cavity «A», cavity «B», they both shared one Backshell, Backshell part number is S6W(F)-1FJ1A. Cavity «C» use S6W(F)-1FJ2A Backshell. Backshell can realize cable clamping and shielding;

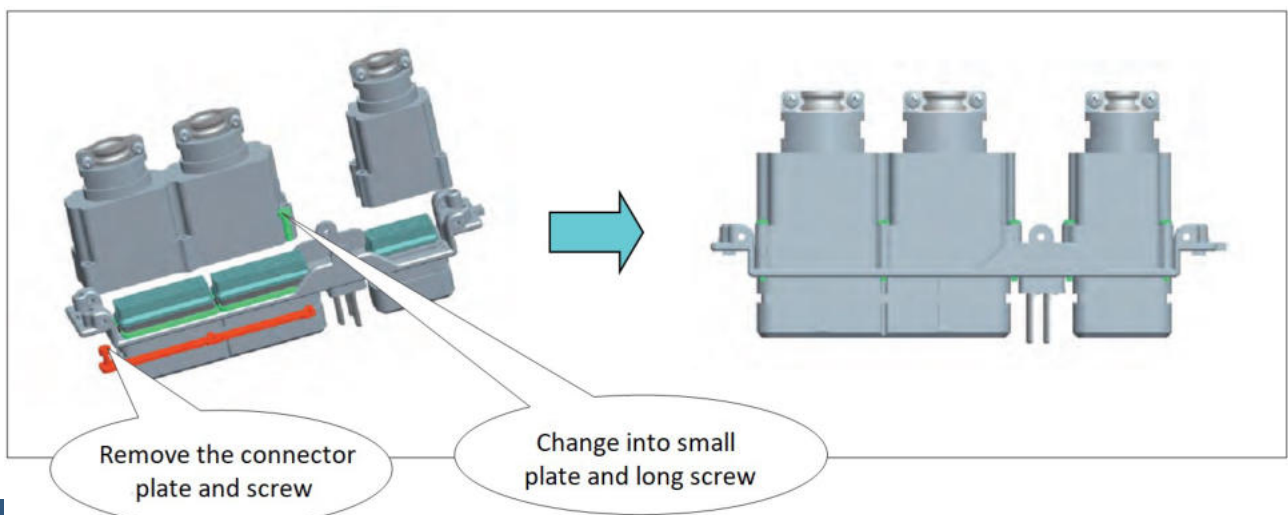

Simple drawing of Backshell structure

S6F(W)-1FJ1A

Used for S6-1 series connector cavity «A» and cavity «B». Realize shielding and cable clamping. For single cavity, cable lead-out diameter ≤ 14 mm

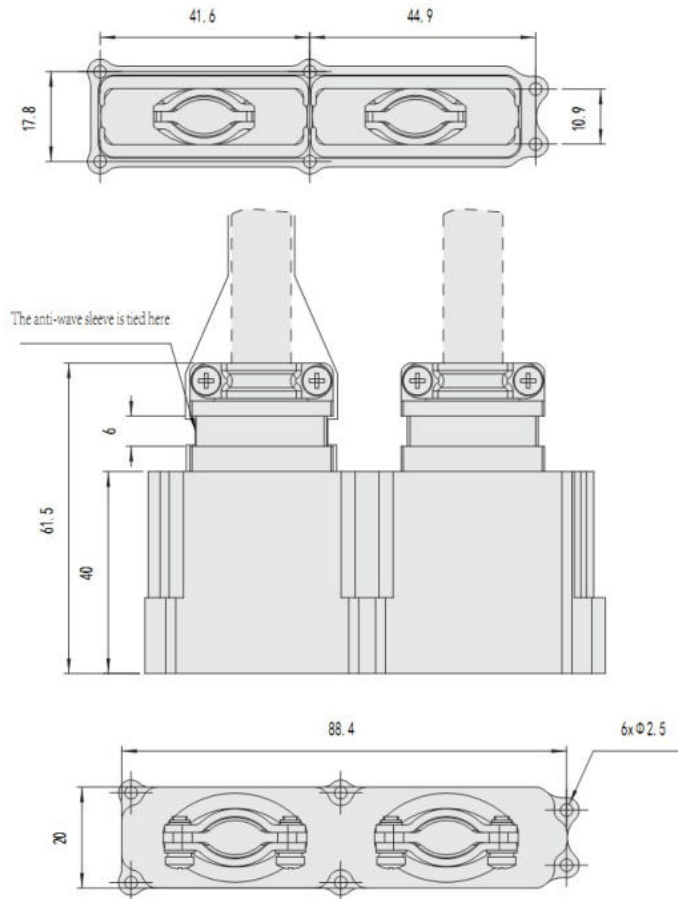

S6F(W)-1FJ2A

Used for S6-1 series connector cavity «C». Realize shielding and cable clamping. For single cavity, cable lead-out diameter ≤ 11 mm

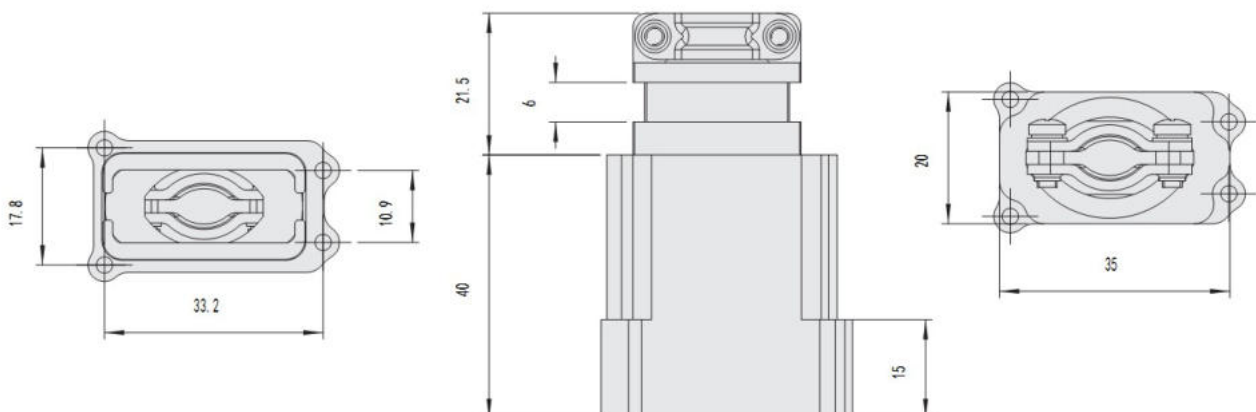

Backshells size 2. Ordering information

Basic series	SB6	F	-2	FJ	1	A
Plating: F = Electroless nickel W = cadmium						
Shell Size = 2						
Product type = Backshell for ARINC600						
Backshell type: 1 = Backshell for cavity A & B 2 = Backshell for cavity C						
Entry position: A = straight lead-out						

NOTE

- In *Backshell* mounting, remove the connector original screws, and change them into the small crimping metal plate and long screw, which are matched with the *Backshell*. And then fix the *Backshell* with the shell. (See the below picture);
- The *Backshell* is ordered separately;
- For S6-2 series product cavity «A», cavity «B», they both shared one *Backshell*, *Backshell* part number is S6W(F)-2FJ1A. Cavity «C» use S6W(F)-2FJ2A *Backshell*. *Backshell* can realize cable clamping and shielding;
- After *Backshell* mounting, mount the tighten screw on *Backshell* lead out straight boot to prevent losing, and can put some thread glue on it. Or use a heat shrink sleeve to protect it;

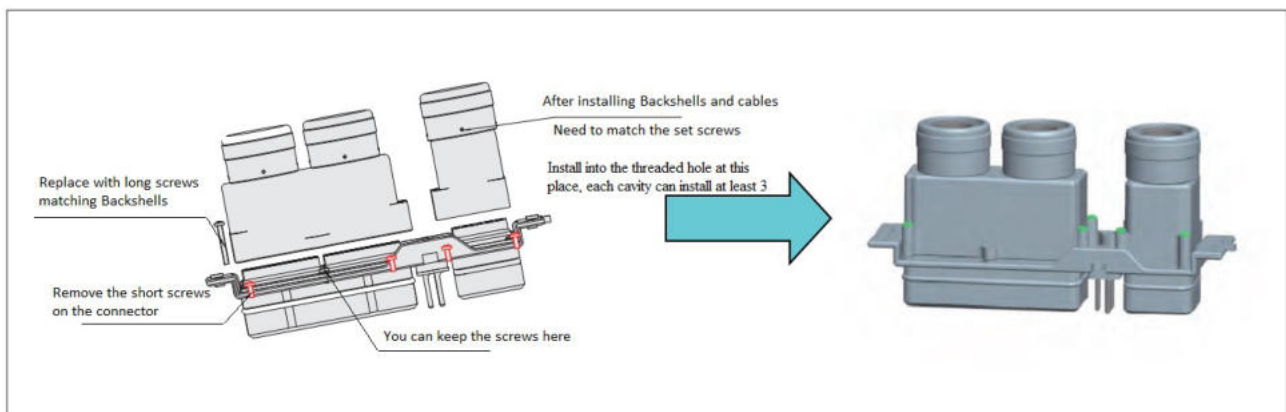

Simple drawing of Backshell structure

S6F(W)-2FJ1A

Used for S6-2 series connector cavity «A» and cavity «B». Realize shielding and cable clamping. Cable lead-out diameter ≤ 20 mm

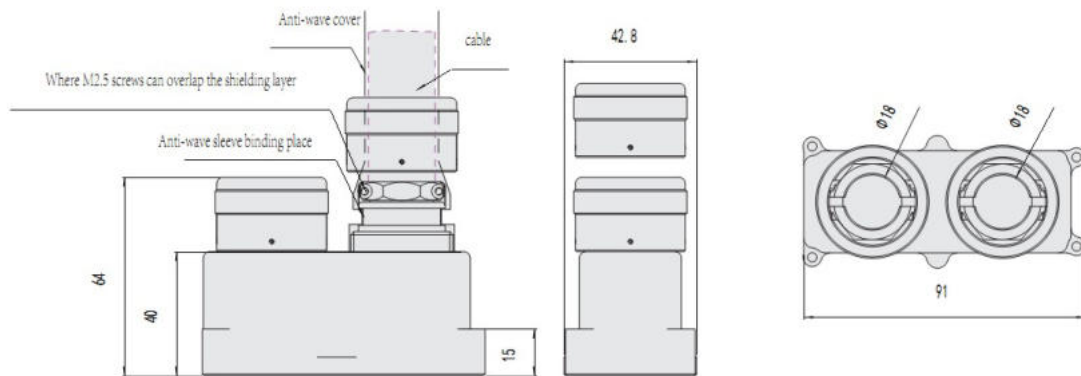

S6F(W)-2FJ2A

Used for S6-2 series connector cavity «C». Realize shielding and cable clamping. Cable lead-out diameter ≤ 20 mm

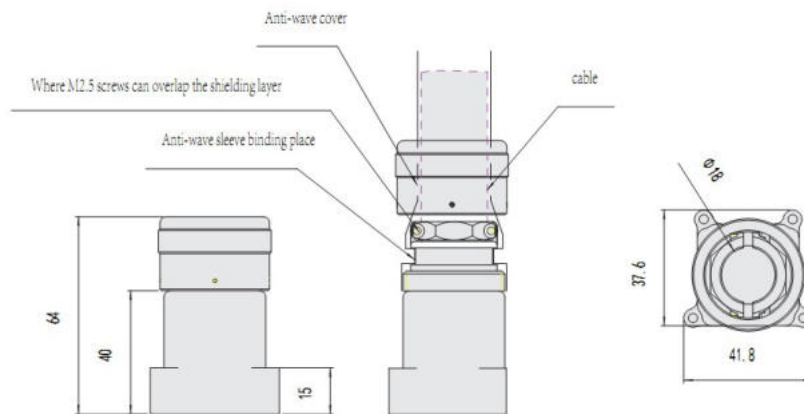

Improved type 360° shielding Backshells Ordering information

Basic series	SB6	F	-2	FJ	1	A	GJ
Plating:							
F = Electroless nickel							
W = cadmium							
Shell Size = 2							
Product type = Backshell for ARINC600							
Backshell type:							
1 = Backshell for cavity A & B							
2 = Backshell for cavity C							
Entry position:							
A = straight lead-out							
GJ = mandatory shielding series index							

NOTE

- In Backshell mounting, remove the connector original screws, and change them into the small crimping metal plate and long screw, which are matched with the Backshell. And then fix the Backshell with the shell. (See the below picture);
- This Backshell has EMI shielding function. It is ordered separately;
- For S6-2 series product cavity «A», cavity «B», they both shared one Backshell, the Backshell part number is S6W(F)-2FJ1AGJ. Cavity «C» use S6W(F)-2FJ2AGJ Backshell. Backshell can realize cable clamping and shielding;
- After the Backshell mounting, mount the tighten screw on the accessory lead out straight boot to prevent losing, and can put some thread glue on it. Or use a heat shrink sleeve to protect it;
- Improved type 360° shielding Backshell has same characteristics with standard type Backshell, except the mounting type;

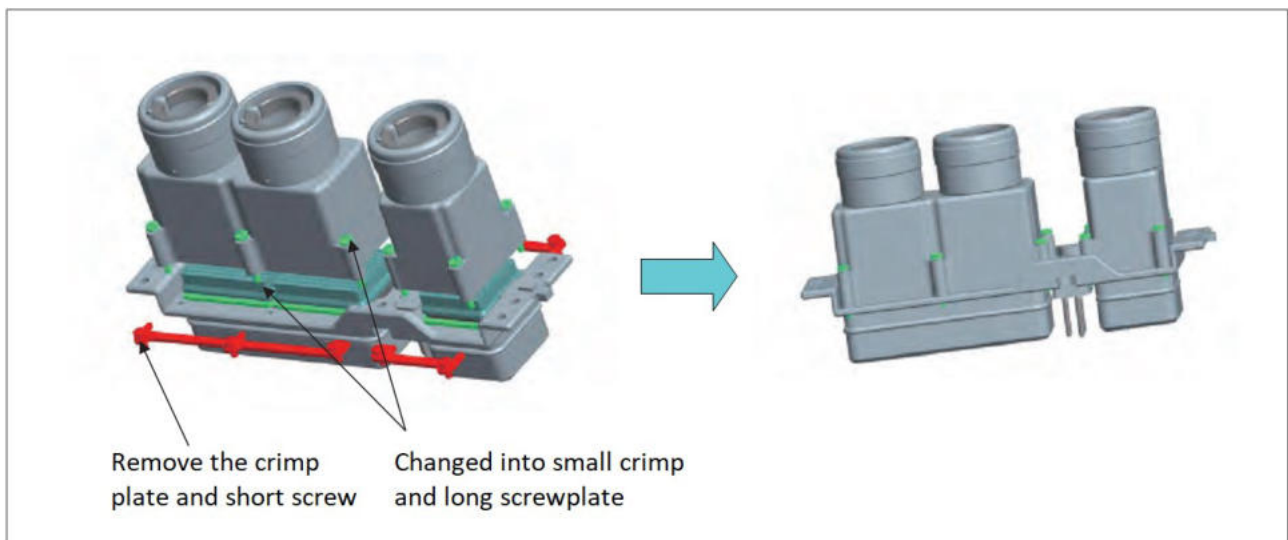

Free lead-out combination Backshell

Ordering information

Basic series	SB6	F	-2	FJ	001
Plating:					
F = Electroless nickel					
W = cadmium					
Shell Size = 2					
Product type = Backshell for ARINC600					
Lead-out combination code					

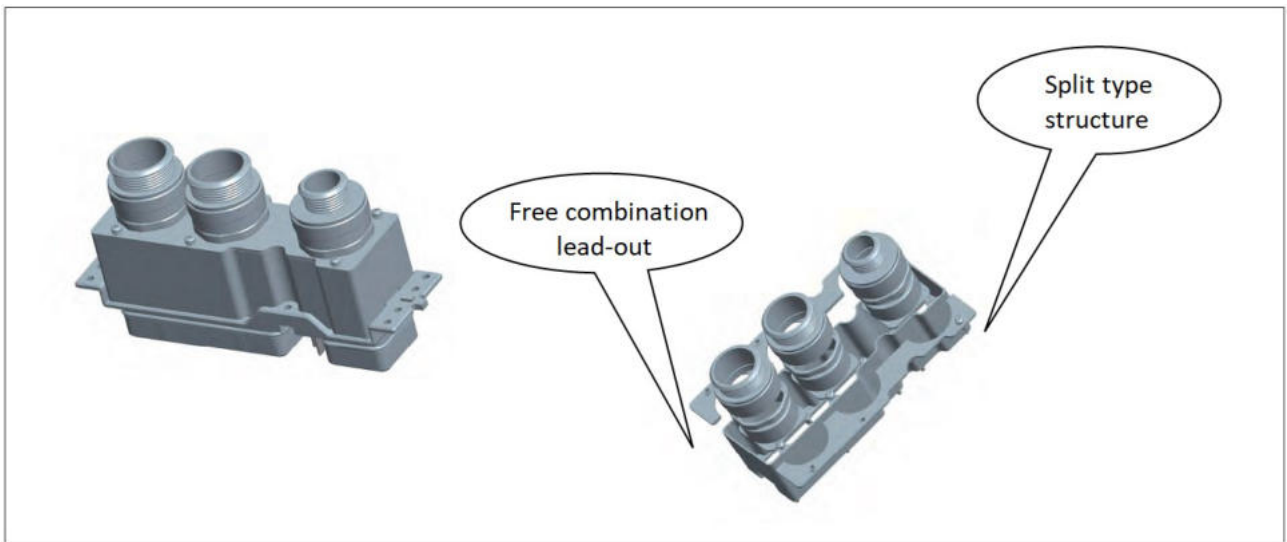

Simple drawing of Backshell structure

S6F(W)-2-FJ-001

Used for S6-2 series connectors. It has shielding and cable clamping function, lead-out can be combined freely. Each cavity has 4 types lead-out: $\varnothing 28$, $\varnothing 25$, $\varnothing 21$, $\varnothing 17$

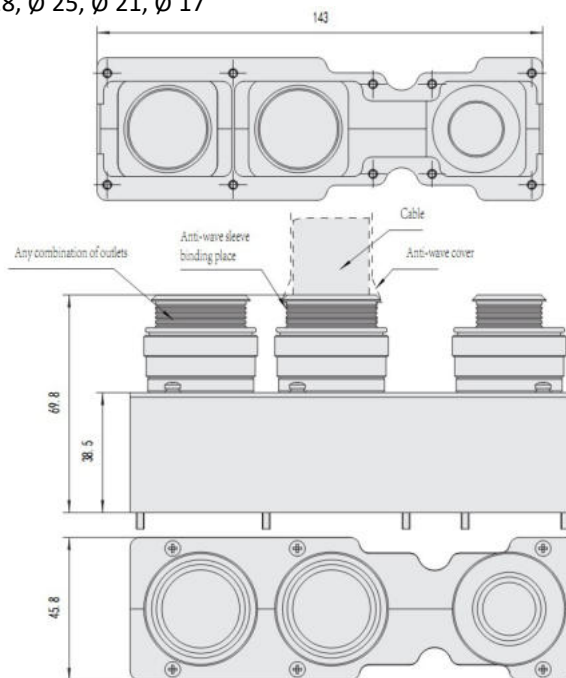



Lead-out combination code

Code	Cavity A	Cavity B	Cavity C	Code	Cavity A	Cavity B	Cavity C
001	Ø 25	Ø 25	Ø 17	002	Ø 28	Ø 28	Ø 28
003	Ø 28	Ø 28	Ø 25	004	Ø 28	Ø 28	Ø 21
005	Ø 28	Ø 28	Ø 17	006	Ø 28	Ø 25	Ø 28
007	Ø 28	Ø 25	Ø 25	008	Ø 28	Ø 25	Ø 21
009	Ø 28	Ø 25	Ø 17	010	Ø 28	Ø 21	Ø 28
011	Ø 28	Ø 21	Ø 25	012	Ø 28	Ø 21	Ø 21
013	Ø 28	Ø 21	Ø 17	014	Ø 28	Ø 17	Ø 28
015	Ø 28	Ø 17	Ø 25	016	Ø 28	Ø 17	Ø 21
017	Ø 28	Ø 17	Ø 17	018	Ø 25	Ø 28	Ø 28
019	Ø 25	Ø 28	Ø 25	020	Ø 25	Ø 28	Ø 21
021	Ø 25	Ø 28	Ø 17	022	Ø 25	Ø 25	Ø 28
023	Ø 25	Ø 25	Ø 25	024	Ø 25	Ø 25	Ø 21
025	Ø 25	Ø 21	Ø 28	026	Ø 25	Ø 21	Ø 25
027	Ø 25	Ø 21	Ø 21	028	Ø 25	Ø 21	Ø 17
029	Ø 25	Ø 17	Ø 28	030	Ø 25	Ø 17	Ø 25
031	Ø 25	Ø 17	Ø 21	032	Ø 25	Ø 17	Ø 17
033	Ø 21	Ø 28	Ø 28	035	Ø 21	Ø 28	Ø 25
035	Ø 21	Ø 28	Ø 21	036	Ø 21	Ø 28	Ø 17
037	Ø 21	Ø 25	Ø 28	038	Ø 21	Ø 25	Ø 25
039	Ø 21	Ø 25	Ø 21	040	Ø 21	Ø 25	Ø 17
041	Ø 21	Ø 21	Ø 28	042	Ø 21	Ø 21	Ø 25
043	Ø 21	Ø 21	Ø 21	044	Ø 21	Ø 21	Ø 17
045	Ø 21	Ø 17	Ø 28	046	Ø 21	Ø 17	Ø 25
047	Ø 21	Ø 17	Ø 21	048	Ø 21	Ø 17	Ø 17
049	Ø 17	Ø 28	Ø 28	050	Ø 17	Ø 28	Ø 25
051	Ø 17	Ø 28	Ø 21	052	Ø 17	Ø 28	Ø 17
053	Ø 17	Ø 25	Ø 28	054	Ø 17	Ø 25	Ø 25
055	Ø 17	Ø 25	Ø 21	056	Ø 17	Ø 25	Ø 17
057	Ø 17	Ø 21	Ø 28	058	Ø 17	Ø 21	Ø 25
059	Ø 17	Ø 21	Ø 21	060	Ø 17	Ø 21	Ø 17
061	Ø 17	Ø 17	Ø 28	062	Ø 17	Ø 17	Ø 25
063	Ø 17	Ø 17	Ø 21	064	Ø 17	Ø 17	Ø 17

Backshells size 3. Ordering information

Basic series	SB6	F	-3	FJ	1	A
Plating: F = Electroless nickel W = cadmium						
Shell Size = 3						
Product type = Backshell for ARINC600						
Backshell type: 1 = Backshell for cavity A, B, E & D 2 = Backshell for cavity C & F						
Entry position: A = straight lead-out						

NOTE

- Backshell mounting type is same with S6-2 series standard Backshell;
- The Backshell is ordered separately;
- For S6-3 series product, cavity «A, B, D, E», they share one Backshell, Backshell part number is S6W(F)-3FJ1A. Cavity «C and F» use S6W(F)-3FJ2A Backshell. Backshell can realize cable clamping and shielding;
- After Backshell mounting, mount the tighten screw on Backshell lead out straight boot to prevent loosing, and can put some thread glue on it. Or use a heat shrink sleeve to protect it;

Simple drawing of Backshell structure

S6F(W)-3-FJ1A

Used for S6-3 series connector cavity «A» and cavity «B». Realize shielding and cable clamping. Cable lead-out diameter ≤ 20 mm

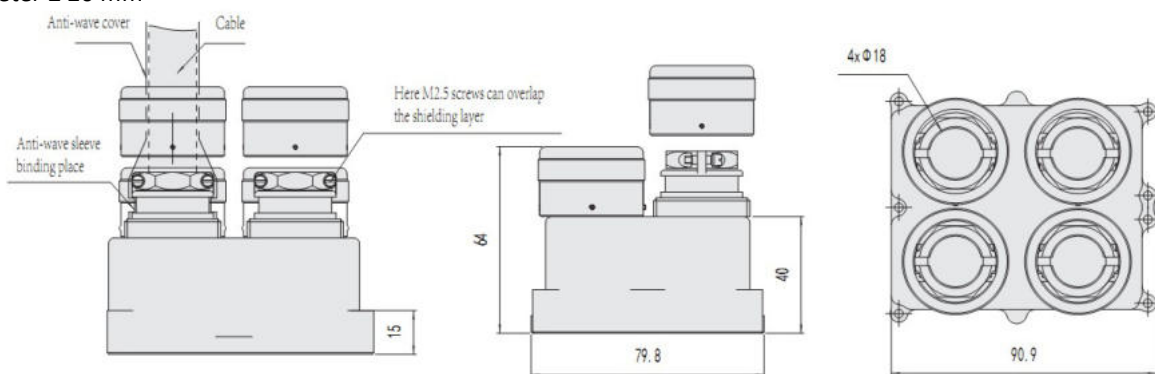

S6F(W)-3-FJ2A

Used for S6-3series connector cavity «C». Realize shielding and cable clamping. Cable lead-out diameter ≤ 20 mm

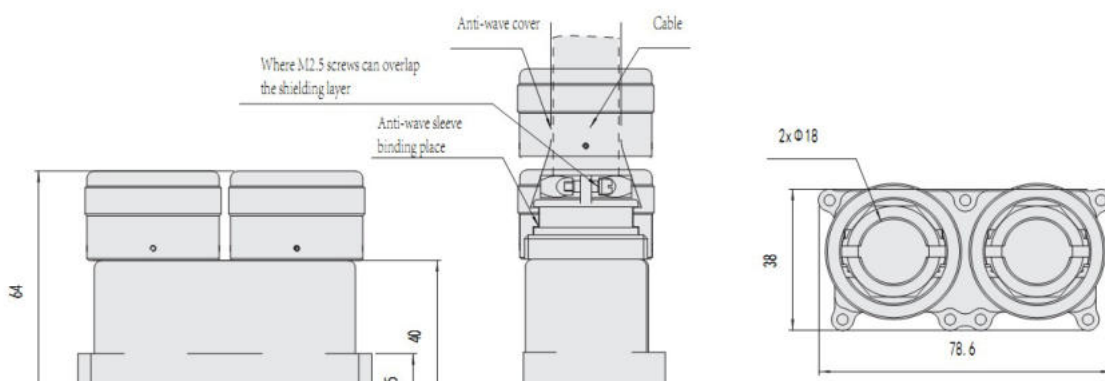

Improved type 360° shielding Backshells Ordering information

Basic series	SB6	F	-3	FJ	1	A	GJ
Plating:							
F = Electroless nickel							
W = cadmium							
Shell Size = 3							
Product type = Backshell for ARINC600							
Backshell type:							
1 = Backshell for cavity A, B, E & D							
2 = Backshell for cavity C & F							
Entry position:							
A = straight lead-out							
GJ = mandatory shielding series index							

NOTE

- In Backshell mounting, remove the connector original crimp plate and screws, and change them into the small crimping metal plate and long screw, which are matched with the Backshell. And then fix the Backshell with the shell. (See the below picture);
- This Backshell has EMI shielding function. It is ordered separately;
- For S6-3 series product, cavity «A, B, D, E», they share one Backshell, the Backshell part number is S6W(F)-3FJ1AGJ. Cavity «C & F» use S6W(F)-3FJ2AGJ Backshell. The Backshell can realize cable clamping and Shielding;
- After the Backshell mounting, mount the tighten screw on the Backshell lead out straight boot to prevent loosening, and can put some thread glue on it. Or use a heat shrink sleeve to protect it;
- Improved type 360° shielding Backshell has same characteristics with standard type Backshell, except the mounting type;

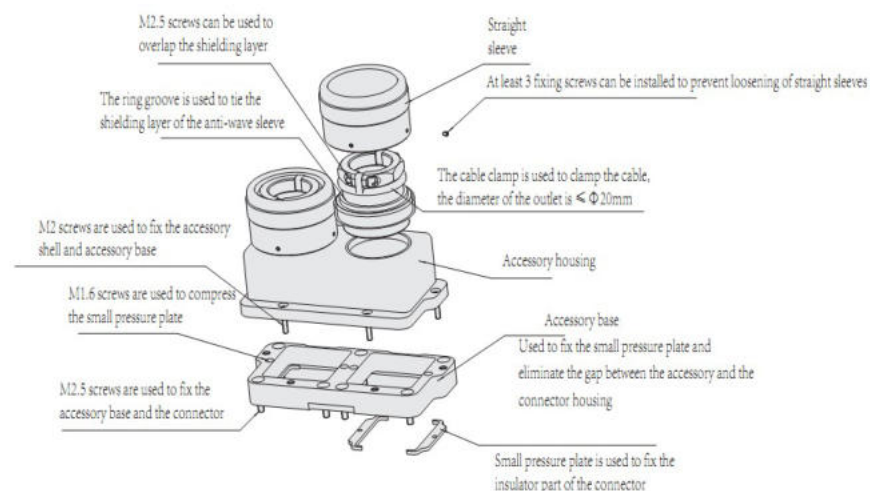

Simple drawing of Backshell structure

S6F(W)-3-FJ1AGJ

Used for S6-3 series connector «A, B, D & E» cavity. Realize shielding and cable clamping. Cable lead-out diameter ≤ 20 mm

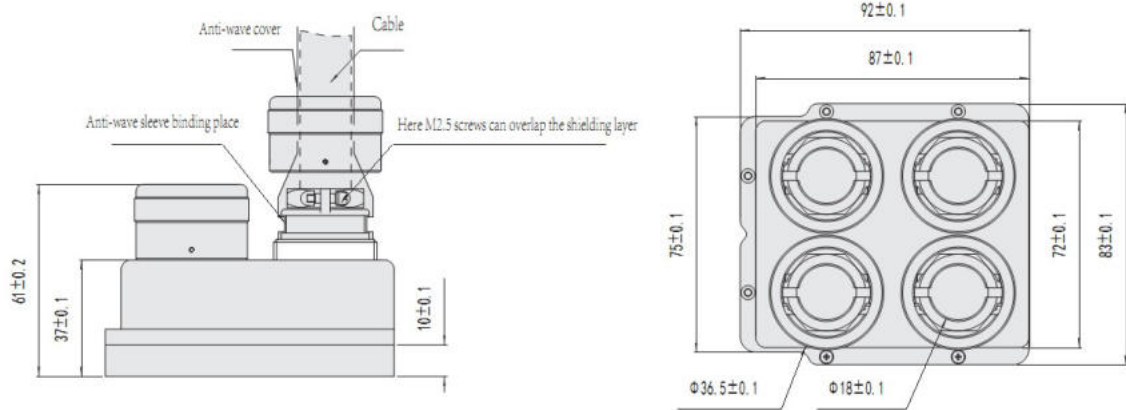

S6F(W)-3-FJ2A

Used for S6-3 series connector cavity «C & F». Realize shielding and cable clamping. Cable lead-out diameter ≤ 20 mm

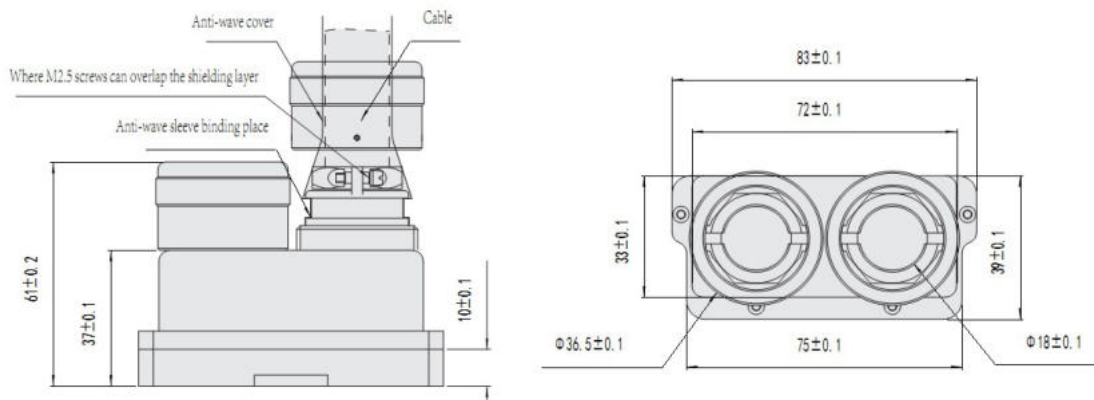

Free lead-out combination Backshell Ordering information

Basic series	SB6	F	-3	FJ	001
Plating:					
F = Electroless nickel					
W = cadmium					
Shell Size = 3					
Product type = Backshell for ARINC600					
Lead-out combination code					

NOTE

- In Backshell mounting, remove the connector original screws, and change them into the small crimping metal plate and long screw, which are matched with the Backshell. And then fix the Backshell with the shell. (See the below picture);
- This Backshell is suitable for the environment has Backshell lead-out and convenient mounting requirement. The product is ordered separately;
- The Backshell adapts split type structure, each cavity lead-out can be combined freely, See Table for combination code detail information;

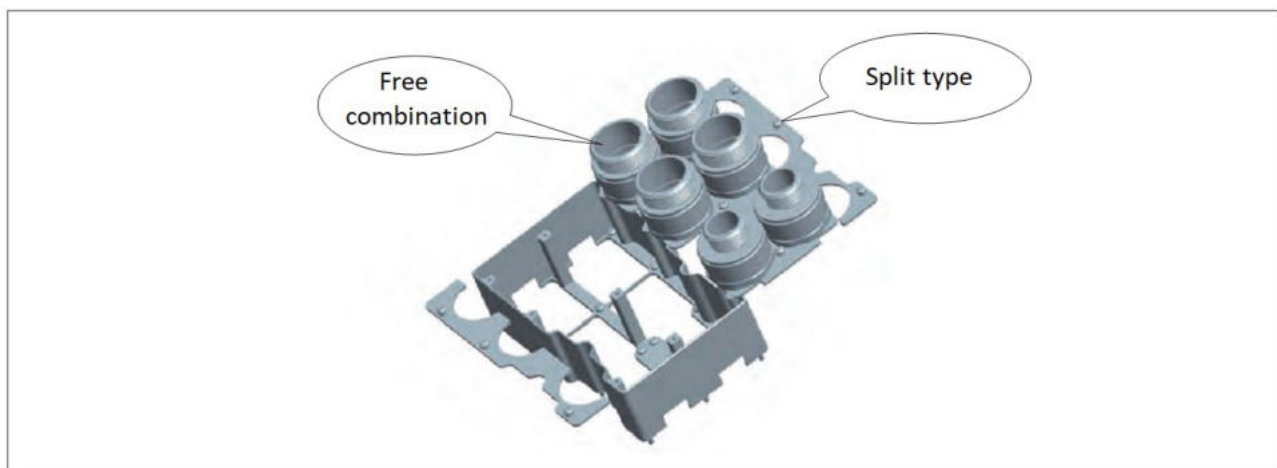

Simple drawing of Backshell structure

S6F(W)-3-FJ-001

Used for S6-3 series connectors. It has shielding and cable clamping function, lead-out can be combined freely. Each cavity has 4 types lead-out: $\varnothing 28$, $\varnothing 25$, $\varnothing 21$, $\varnothing 17$

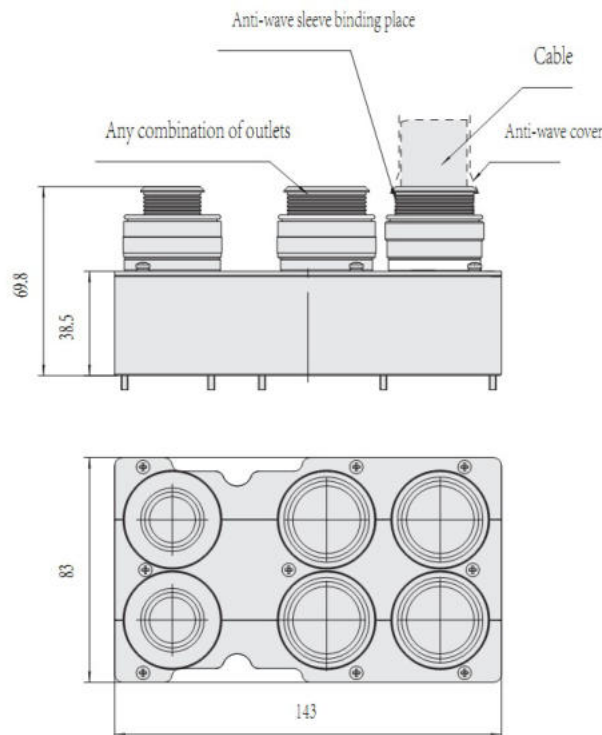

Lead-out combination code

Code	Cavity A	Cavity B	Cavity C	Cavity D	Cavity E	Cavity F
001	$\varnothing 25$	$\varnothing 25$	$\varnothing 25$	$\varnothing 25$	$\varnothing 17$	$\varnothing 17$
002	$\varnothing 28$	$\varnothing 28$	$\varnothing 28$	$\varnothing 28$	$\varnothing 28$	$\varnothing 28$
003	$\varnothing 28$	$\varnothing 28$	$\varnothing 28$	$\varnothing 28$	$\varnothing 28$	$\varnothing 25$
004	$\varnothing 28$	$\varnothing 28$	$\varnothing 28$	$\varnothing 28$	$\varnothing 28$	$\varnothing 21$
005	$\varnothing 28$	$\varnothing 28$	$\varnothing 28$	$\varnothing 28$	$\varnothing 28$	$\varnothing 17$
006	$\varnothing 28$	$\varnothing 28$	$\varnothing 28$	$\varnothing 28$	$\varnothing 25$	$\varnothing 28$
007	$\varnothing 28$	$\varnothing 28$	$\varnothing 28$	$\varnothing 28$	$\varnothing 25$	$\varnothing 25$
008	$\varnothing 28$	$\varnothing 28$	$\varnothing 28$	$\varnothing 28$	$\varnothing 25$	$\varnothing 21$
009	$\varnothing 28$	$\varnothing 28$	$\varnothing 28$	$\varnothing 28$	$\varnothing 25$	$\varnothing 17$
010	$\varnothing 28$	$\varnothing 28$	$\varnothing 28$	$\varnothing 28$	$\varnothing 21$	$\varnothing 28$
011	$\varnothing 28$	$\varnothing 28$	$\varnothing 28$	$\varnothing 28$	$\varnothing 21$	$\varnothing 25$
012	$\varnothing 28$	$\varnothing 28$	$\varnothing 28$	$\varnothing 28$	$\varnothing 21$	$\varnothing 21$
013	$\varnothing 28$	$\varnothing 28$	$\varnothing 28$	$\varnothing 28$	$\varnothing 21$	$\varnothing 17$
014	$\varnothing 28$	$\varnothing 28$	$\varnothing 28$	$\varnothing 28$	$\varnothing 17$	$\varnothing 28$



015	Ø 28	Ø 28	Ø 28	Ø 28	Ø 17	Ø 25
016	Ø 28	Ø 28	Ø 28	Ø 28	Ø 17	Ø 21
017	Ø 28	Ø 28	Ø 28	Ø 28	Ø 17	Ø 17

Code	Cavity A	Cavity B	Cavity C	Cavity D	Cavity E	Cavity F
018	Ø 28	Ø 28	Ø 28	Ø 25	Ø 25	Ø 25
019	Ø 28	Ø 28	Ø 28	Ø 25	Ø 25	Ø 17
020	Ø 28	Ø 28	Ø 28	Ø 25	Ø 21	Ø 21
021	Ø 28	Ø 28	Ø 28	Ø 25	Ø 21	Ø 17
022	Ø 28	Ø 28	Ø 28	Ø 25	Ø 17	Ø 17
023	Ø 28	Ø 28	Ø 28	Ø 21	Ø 21	Ø 21
024	Ø 28	Ø 28	Ø 28	Ø 21	Ø 21	Ø 17
025	Ø 28	Ø 28	Ø 28	Ø 21	Ø 17	Ø 17
026	Ø 28	Ø 28	Ø 28	Ø 17	Ø 17	Ø 17
027	Ø 28	Ø 28	Ø 25	Ø 25	Ø 25	Ø 25
028	Ø 28	Ø 28	Ø 25	Ø 25	Ø 25	Ø 21
029	Ø 28	Ø 28	Ø 25	Ø 25	Ø 25	Ø 17
030	Ø 28	Ø 28	Ø 25	Ø 25	Ø 21	Ø 21
031	Ø 28	Ø 28	Ø 25	Ø 25	Ø 21	Ø 17
032	Ø 28	Ø 28	Ø 25	Ø 25	Ø 17	Ø 17
033	Ø 28	Ø 28	Ø 25	Ø 21	Ø 21	Ø 17
034	Ø 28	Ø 28	Ø 25	Ø 21	Ø 21	Ø 17
035	Ø 28	Ø 28	Ø 25	Ø 21	Ø 17	Ø 17
036	Ø 28	Ø 28	Ø 25	Ø 17	Ø 17	Ø 17
037	Ø 28	Ø 28	Ø 21	Ø 21	Ø 21	Ø 21
038	Ø 28	Ø 28	Ø 21	Ø 21	Ø 21	Ø 17
039	Ø 28	Ø 28	Ø 21	Ø 21	Ø 17	Ø 17
040	Ø 28	Ø 28	Ø 21	Ø 17	Ø 17	Ø 17
041	Ø 28	Ø 28	Ø 17	Ø 17	Ø 17	Ø 17
042	Ø 28	Ø 25	Ø 25	Ø 25	Ø 25	Ø 25
043	Ø 28	Ø 25	Ø 25	Ø 25	Ø 25	Ø 21
044	Ø 28	Ø 25	Ø 17	Ø 25	Ø 25	Ø 17
045	Ø 28	Ø 25	Ø 25	Ø 25	Ø 25	Ø 17
046	Ø 28	Ø 25	Ø 25	Ø 25	Ø 21	Ø 21
047	Ø 28	Ø 25	Ø 25	Ø 25	Ø 21	Ø 17
048	Ø 28	Ø 25	Ø 25	Ø 25	Ø 17	Ø 17
049	Ø 28	Ø 25	Ø 25	Ø 21	Ø 21	Ø 21
050	Ø 28	Ø 25	Ø 25	Ø 21	Ø 21	Ø 17
051	Ø 28	Ø 25	Ø 25	Ø 21	Ø 17	Ø 17
052	Ø 28	Ø 25	Ø 25	Ø 17	Ø 17	Ø 17
053	Ø 28	Ø 25	Ø 21	Ø 21	Ø 21	Ø 21
054	Ø 28	Ø 25	Ø 21	Ø 21	Ø 21	Ø 17
055	Ø 28	Ø 25	Ø 21	Ø 21	Ø 17	Ø 17
056	Ø 28	Ø 25	Ø 21	Ø 17	Ø 17	Ø 17
057	Ø 28	Ø 25	Ø 17	Ø 17	Ø 17	Ø 17
058	Ø 28	Ø 21	Ø 21	Ø 21	Ø 21	Ø 21



059	Ø 28	Ø 21	Ø 21	Ø 21	Ø 21	Ø 17
060	Ø 28	Ø 21	Ø 21	Ø 21	Ø 17	Ø 17
061	Ø 28	Ø 21	Ø 21	Ø 17	Ø 17	Ø 17
062	Ø 28	Ø 21	Ø 17	Ø 17	Ø 17	Ø 17

Code	Cavity A	Cavity B	Cavity C	Cavity D	Cavity E	Cavity F
063	Ø 28	Ø 17	Ø 17	Ø 17	Ø 17	Ø 17
064	Ø 25	Ø 25	Ø 25	Ø 25	Ø 25	Ø 25
065	Ø 25	Ø 25	Ø 25	Ø 25	Ø 25	Ø 21
066	Ø 25	Ø 25	Ø 25	Ø 25	Ø 25	Ø 17
067	Ø 25	Ø 25	Ø 25	Ø 25	Ø 21	Ø 21
068	Ø 25	Ø 25	Ø 25	Ø 25	Ø 25	Ø 17
069	Ø 25	Ø 25	Ø 25	Ø 21	Ø 21	Ø 21
070	Ø 25	Ø 25	Ø 25	Ø 21	Ø 21	Ø 17
071	Ø 25	Ø 25	Ø 25	Ø 21	Ø 17	Ø 17
072	Ø 25	Ø 25	Ø 25	Ø 17	Ø 17	Ø 17
073	Ø 25	Ø 25	Ø 21	Ø 21	Ø 21	Ø 21
074	Ø 25	Ø 25	Ø 21	Ø 21	Ø 21	Ø 17
075	Ø 25	Ø 25	Ø 21	Ø 21	Ø 17	Ø 17
076	Ø 25	Ø 25	Ø 21	Ø 17	Ø 17	Ø 17
077	Ø 25	Ø 25	Ø 17	Ø 17	Ø 17	Ø 17
078	Ø 25	Ø 21	Ø 21	Ø 21	Ø 21	Ø 21
079	Ø 25	Ø 21	Ø 21	Ø 21	Ø 21	Ø 17
080	Ø 25	Ø 21	Ø 21	Ø 21	Ø 17	Ø 17
081	Ø 25	Ø 21	Ø 21	Ø 17	Ø 17	Ø 17
082	Ø 25	Ø 21	Ø 17	Ø 17	Ø 17	Ø 17
083	Ø 25	Ø 17	Ø 17	Ø 17	Ø 17	Ø 17
084	Ø 21	Ø 21	Ø 21	Ø 21	Ø 21	Ø 21
085	Ø 21	Ø 21	Ø 21	Ø 21	Ø 21	Ø 17
086	Ø 21	Ø 21	Ø 21	Ø 21	Ø 17	Ø 17
087	Ø 21	Ø 21	Ø 21	Ø 17	Ø 17	Ø 17
088	Ø 21	Ø 21	Ø 17	Ø 17	Ø 17	Ø 17
089	Ø 21	Ø 17	Ø 17	Ø 17	Ø 17	Ø 17
090	Ø 17	Ø 17	Ø 17	Ø 17	Ø 17	Ø 17
091	Ø 17	Ø 28	Ø 17	Ø 28	Ø 17	Ø 17
092	Ø 17	Ø 25	Ø 17	Ø 25	Ø 17	Ø 17
093	Ø 17	Ø 21	Ø 17	Ø 21	Ø 17	Ø 17
094	Ø 17	Ø 25	Ø 25	Ø 17	Ø 17	Ø 17
095	Ø 17	Ø 17	Ø 21	Ø 17	Ø 17	Ø 17
096	Ø 17	Ø 17	Ø 17	Ø 28	Ø 28	Ø 17
097	Ø 17	Ø 17	Ø 17	Ø 25	Ø 25	Ø 17
098	Ø 17	Ø 17	Ø 17	Ø 21	Ø 21	Ø 17
099	Ø 17	Ø 17	Ø 17	Ø 21	Ø 17	Ø 17



CÔNG TY TNHH RỒNG VÀNG TECHNOLOGY

**Địa chỉ: 48/5 Phong Chau str,
Nam Nha Trang Ward,**

Khanh Hoa Province, Vietnam, 57123

Sđt: +84 79.219.2707

www.rong-vang-technology.vn